

N.B. - MONTARE LE SPAZZOLE SOLO SU QUESTO LATO

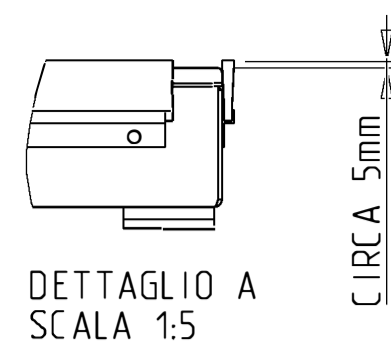

N.B. - MONTARE LE SPAZZOLE ANCHE SUL LATO OPPOSTO

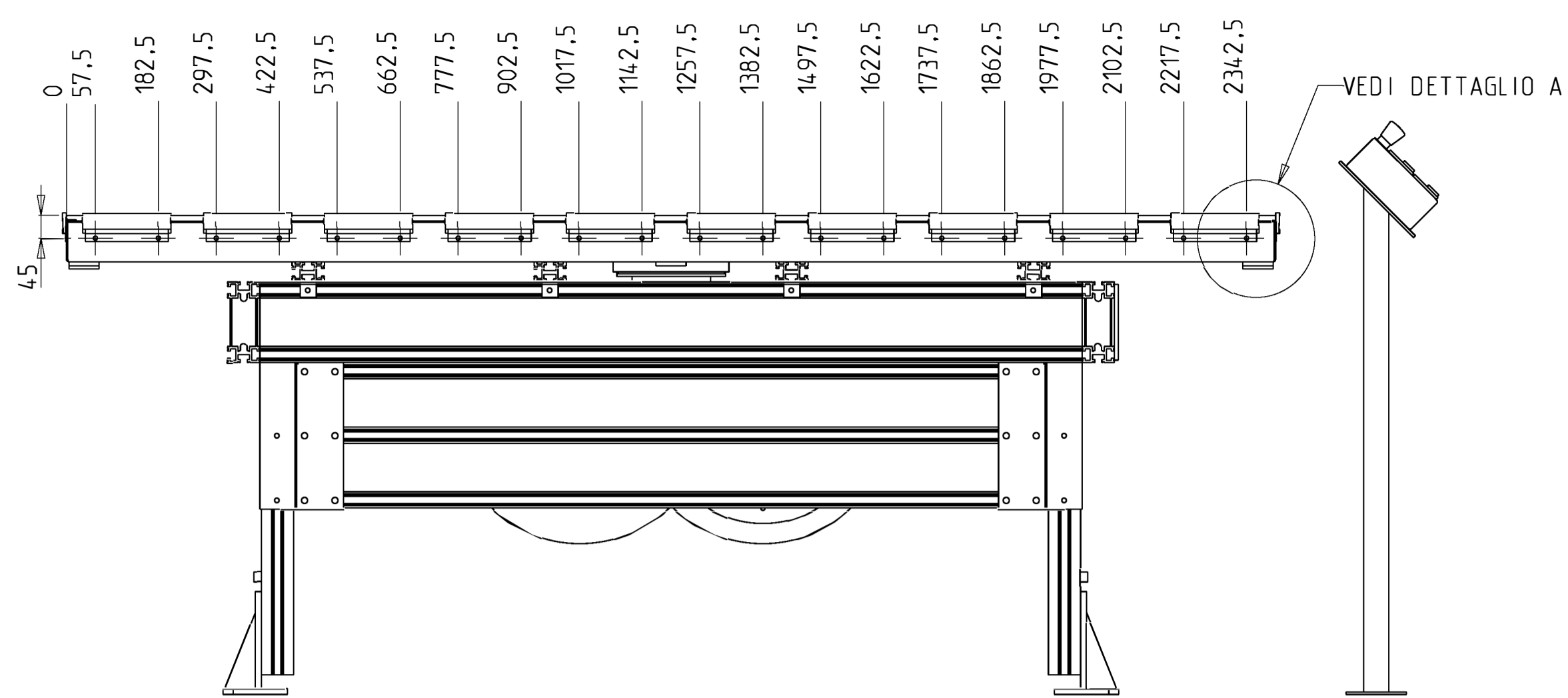
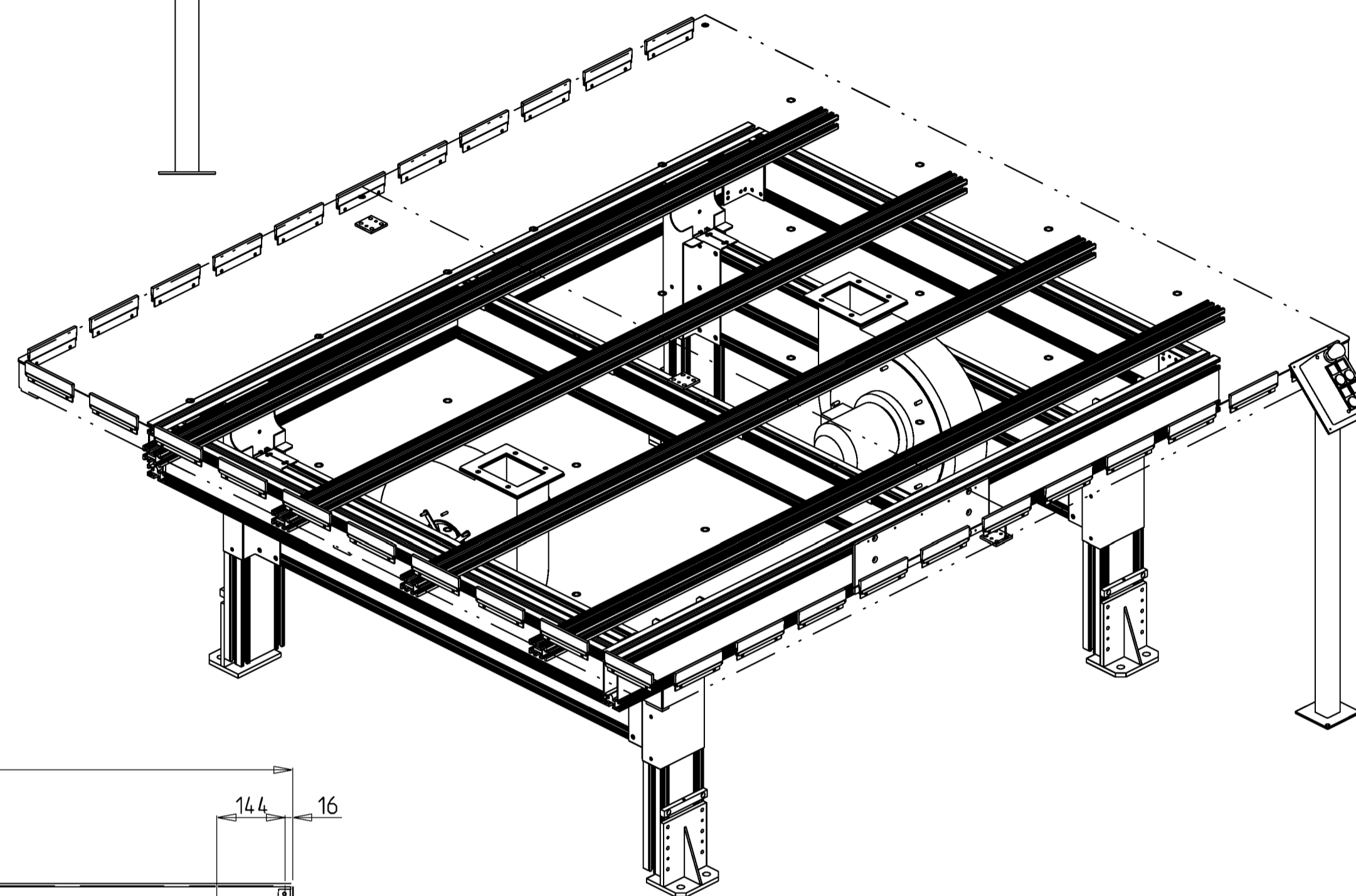
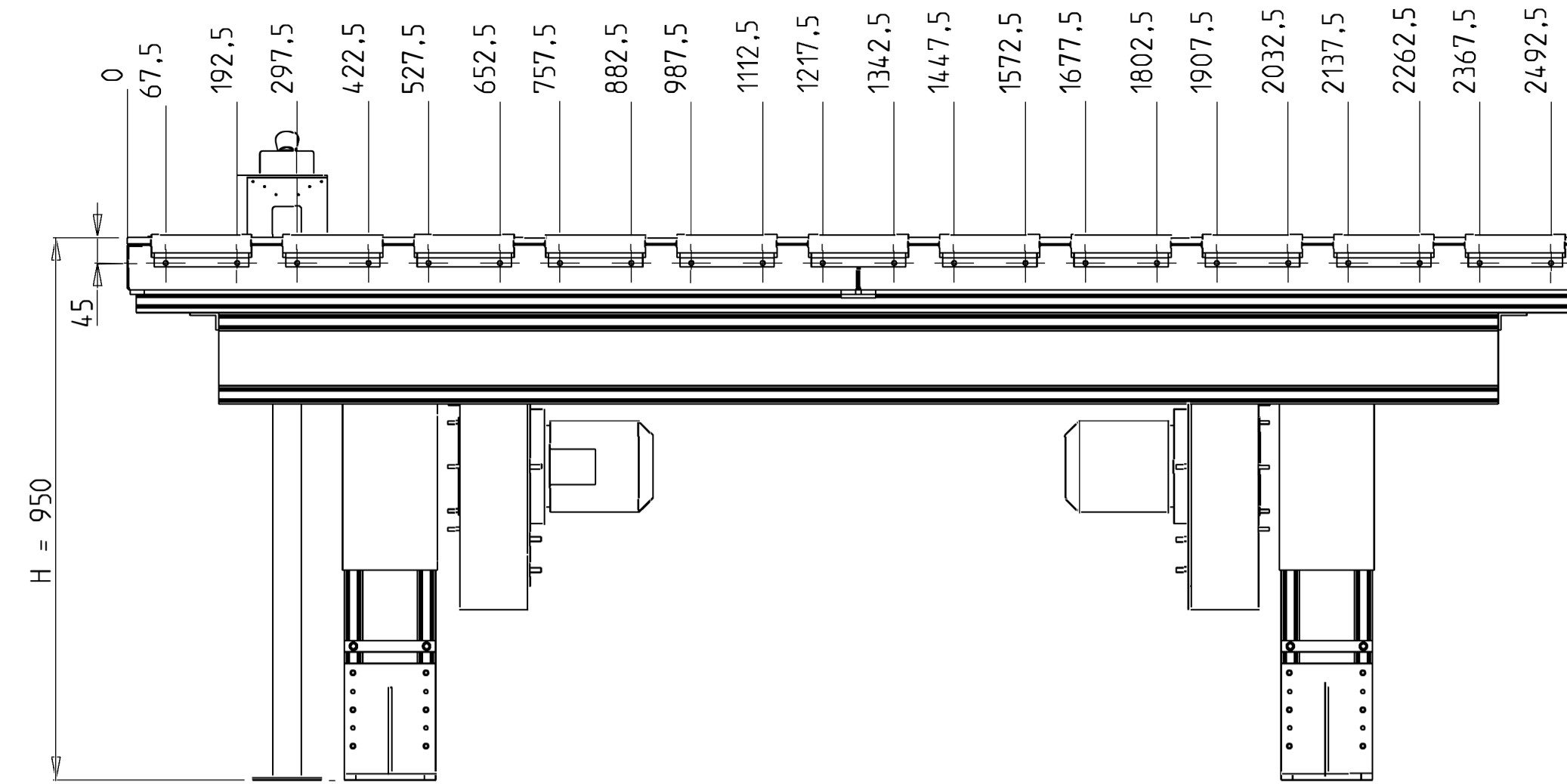

VISTA DA SOTTO

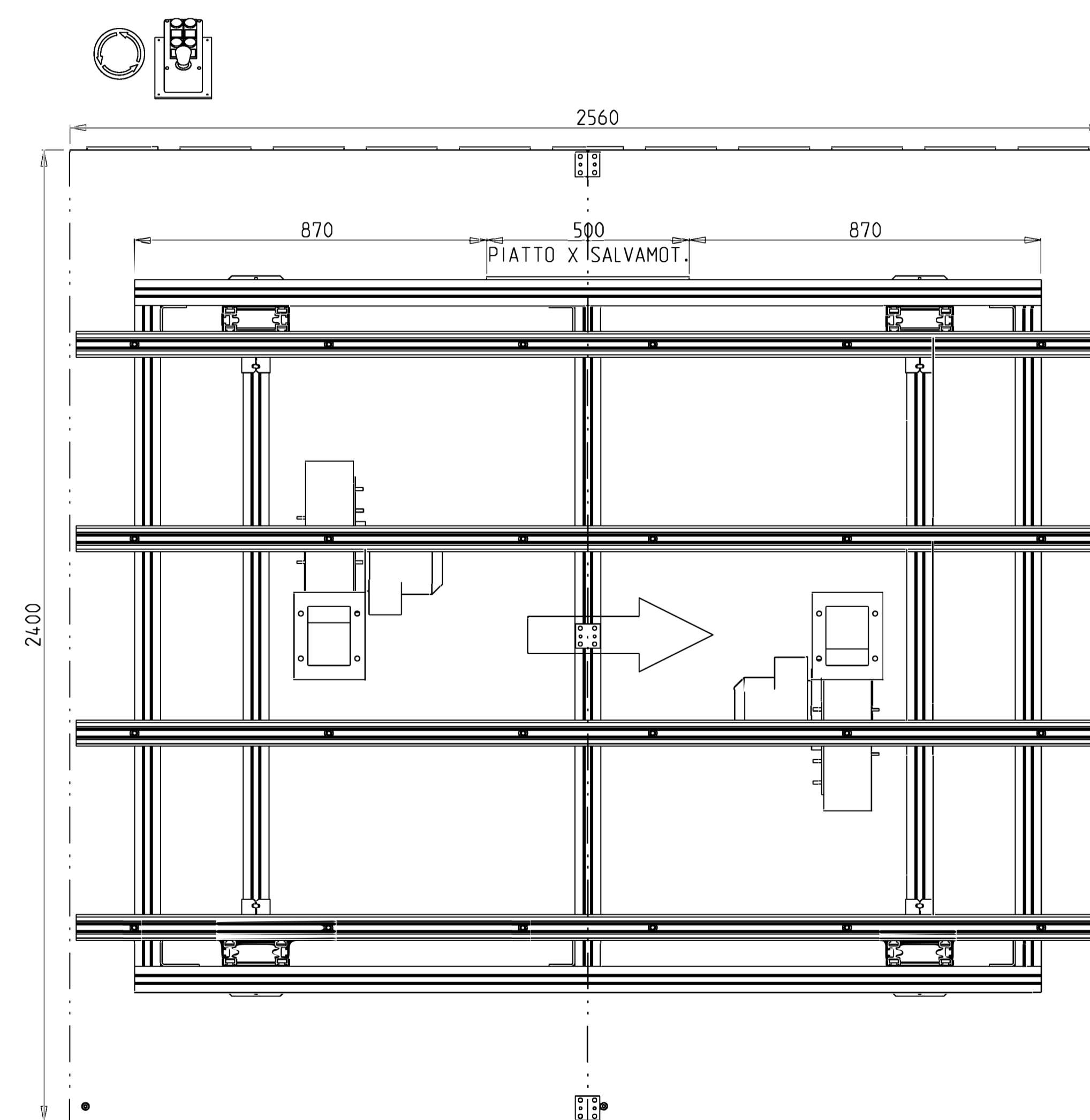
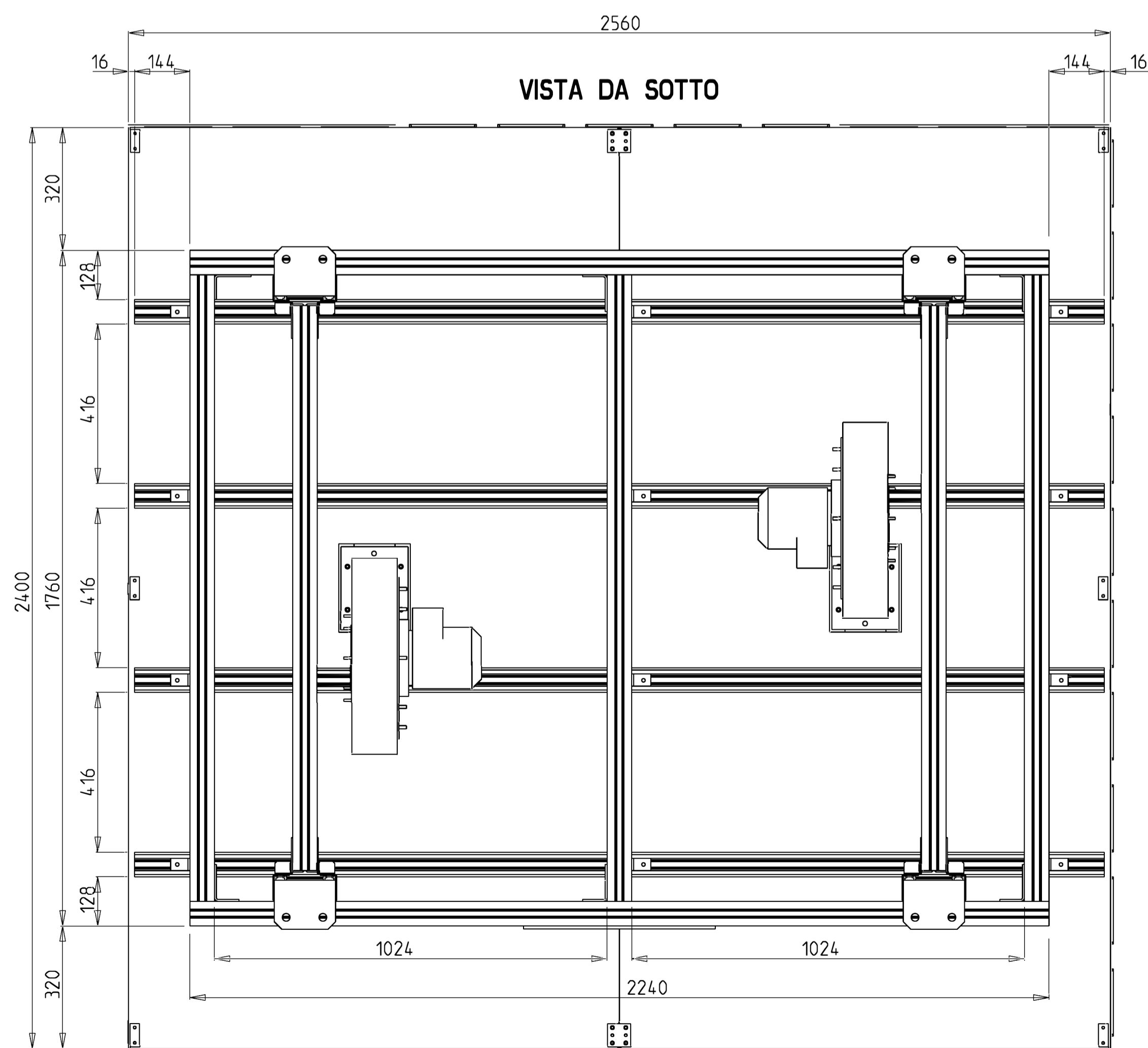

CONSUMI
POTENZA ASSORBITA MAX: 1.5 Kw. 400V 50Hz
CONSUMPTION
ABSORBED ELECTRICAL POWER MAX. 1.5 Kw. 400V 50Hz
CONSUMATIONS
PUISSANCE ABSORBE MAX . 1.5 Kw. 400 V 50 Hz
VERBRAUCH
AFGENOMMENE ENERGIE MAX. 1.5 Kw. 400V 50Hz
CONSUMO
POTENCIA ELECTRICA MAX. 1.5 Kw. 400V 50Hz

Macchina con DICHIARAZIONE DEL FABBRICANTE (ALL. 2B)
Machine with DECLARATION OF THE MANUFACTURER (ALL. 2B)
Macchina con DECLARATION DU FRABRIQUANT (ALL. 2B)
Maschine mit HERSTELLERERHLARUNG (ALL. 2B)
Macchina con DECLARACION DEL FABRICANTE (ALL. 2B)

Disegnatore: FerWood spa		FerWood BRILLIANT SOLUTIONS FOR WOOD <small>FerWood spa - Via Langhe 4/A 12047 Pellenzo (CN) Italy Tel: +39 0172 474073 - Fax: +39 0172 471642 email: info@ferwoodgroup.com</small>
Titolo: 005607_La		
Descrizione:		
Data: 02/12/24	Sistema:	Foglio: A3
Tutti i diritti sono riservati da Copyright. vietata la riproduzione. All rights reserved by Copyright. is forbidden to reproduce.		