

Optimat BHX 500 CNC-Processing Center



Optimat | profi line | power line



Optimat BHX 500

Workpiece dimensions:

Length:

max. 2500 (3000*) mm
min. 200 mm

Width:

max. 1000 (1300**) mm
min. 70 mm

Height:

max. 80 mm (2 x 40 mm)
min. 4 mm

* option

** under consideration of the travelling ranges

The **Optimat BHX 500** enables simultaneous processing of both sides of cupboards. Hereby it is possible to manufacture identical or mirrored parts in a single processing and clamping step.

The **Optimat BHX 500** Concept is based on the idea of dividing the machine into 3 technology ranges: the loading area, processing area and withdrawal area. Hereby the gained independence optimizes the processing steps in terms of quality and time.

To fulfil the customers expectations and raise the production output within the same time interval and also maintain the same quality the **Optimat BHX 500** is equipped with a special power package. High-Speed processing aggregates up to 7500 RPM accelerate the axes up to 10m/sec and the processing speeds up to 130m/min hereby permanently keeping this machine in motion.

Despite high occurring kinetic energy the quality of the processed parts is maintained on the highest level. Consequently the **Optimat BHX 500** emphasises complete and efficient CNC-Technology with which all common challenges are achieved quickly and precisely.

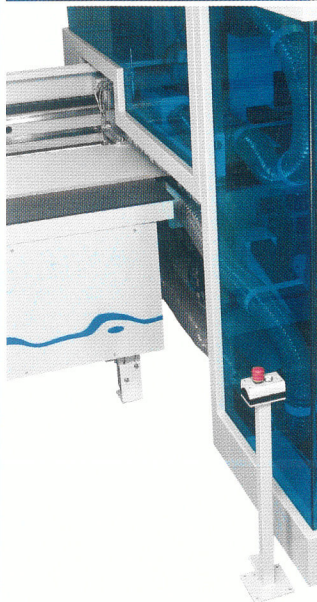
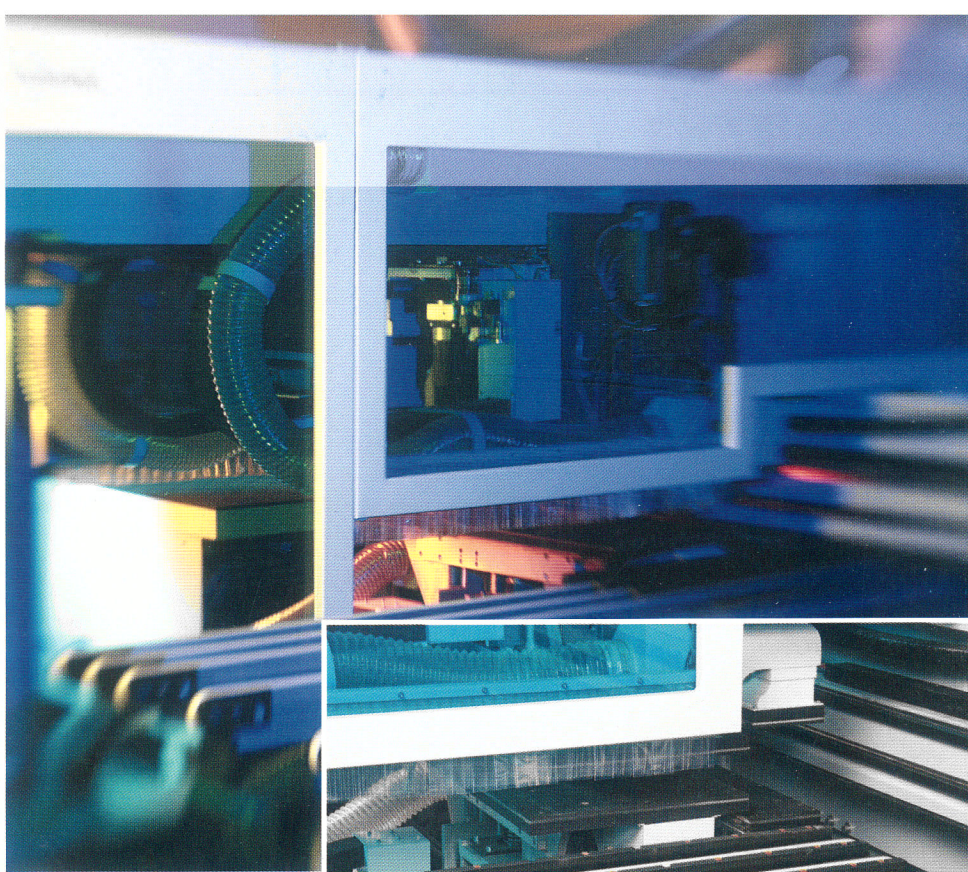

Highlights:

- Smooth-Pressure® System
- TBO-System®
- »The simple way« – optimal access to the processing aggregates
- Interface for handling solutions (e.g. robots, portal feeder etc.)
- 5-sided processing of the workpieces
- Double panel processing in one step
- Workpiece thickness up to 80 mm
- Measuring of the workpiece length and thickness
- Driving speeds up to 130 m/min
- High-Speed drilling (1500 - 7500 RPM)
- Automatic spindle clamping system - patented
- Sealed »long-life« linear guiding system
- Selectable operator side

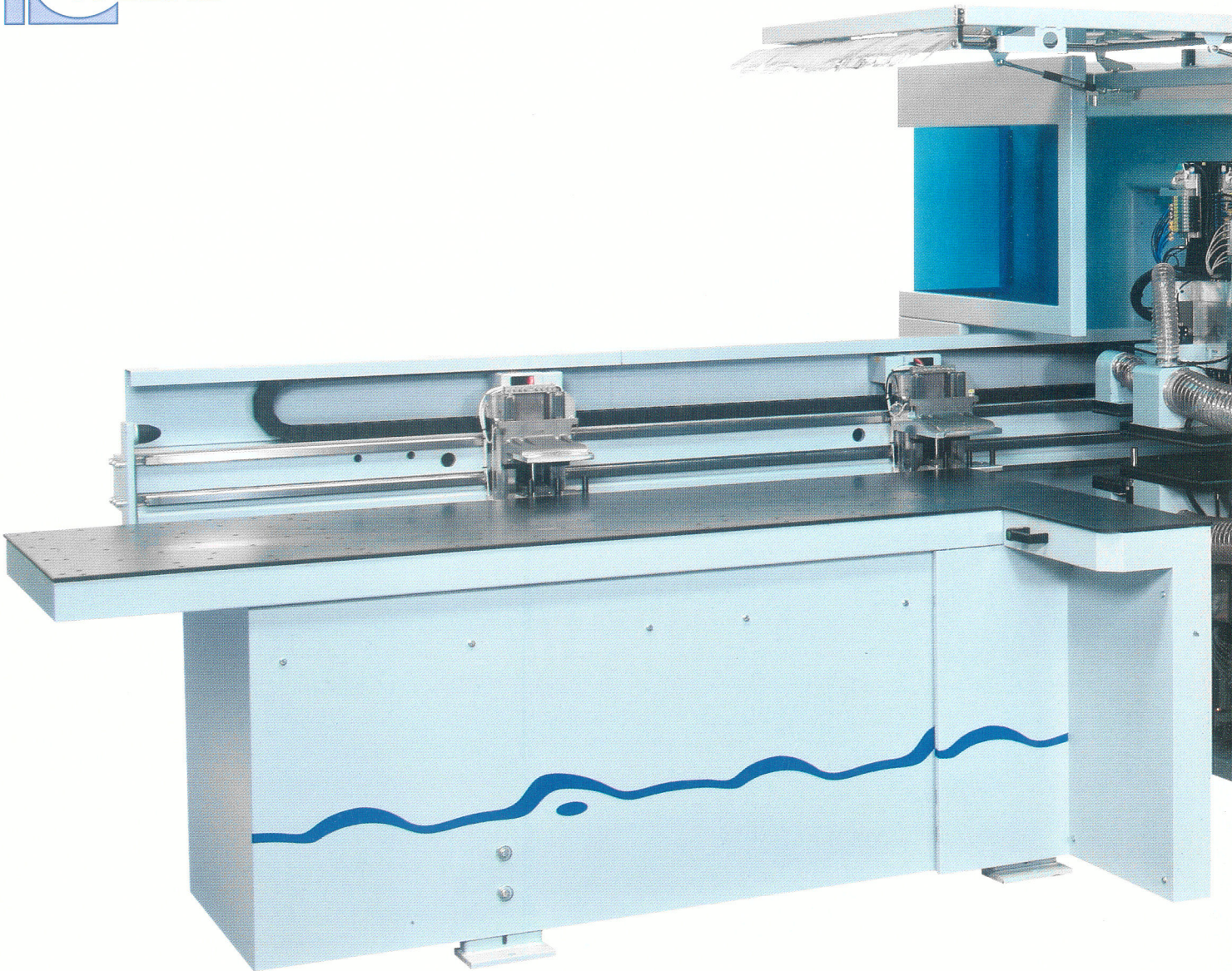

Configuration

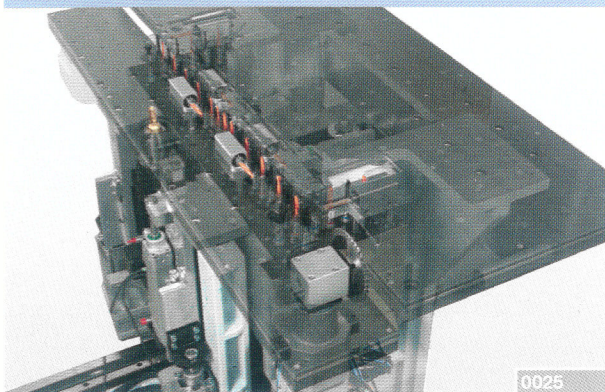

- Spindles: 2 x 32 vertical
- 2 x 8 horizontal in X
- 2 x 2 horizontal in Y
- Grooving saw: 2 x 90° swivable in X- and Y-direction
- Routing spindle: 2 x 6 kW ETP

Clamping-Device-System

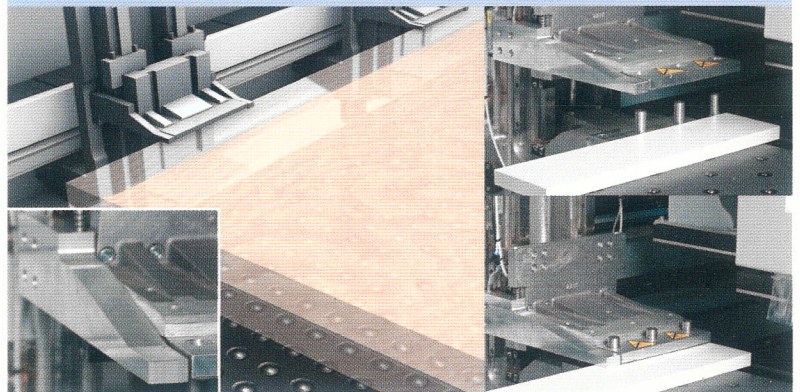

- Fast and precise - no set-up times
- Integrated measuring system for workpiece thickness and length
- Secure positioning via program-controlled AC-servodrive
- Workpiece thickness up to 80 mm (2 x 40 mm)



Outfeeding section

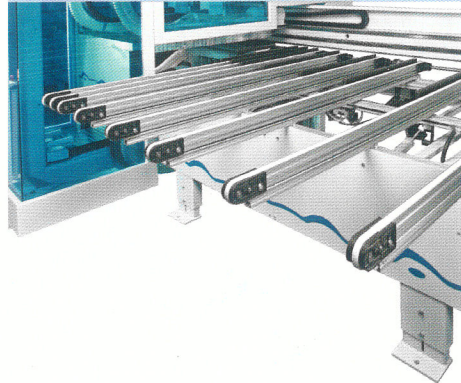

- Frequency-controlled outfeed transport
- Material-protective handling via 8 electro-pneumatic controlled disengaging devices

Smooth-Pressure® System

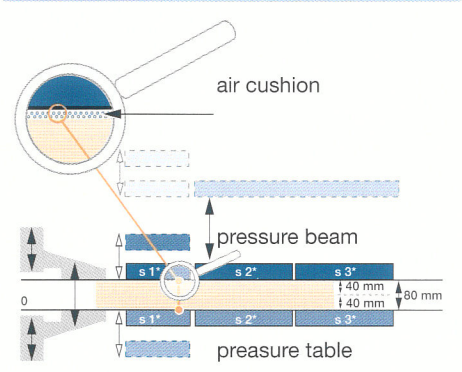

- The pressure beam and the pressure table create a small but very solid air cushion → optimal and smooth feeding of the workpieces
- Controlled air consumption

»The simple way«

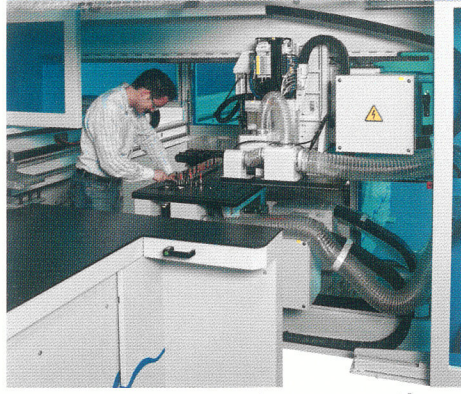

If necessary the operator receives quick and simple access to the processing aggregates

All inclusive – the Standards

power control



- TFT-Display
- CD-RW device
- Modem
- USB frontside bus

- Ethernet connection 10/100 Mbit
- Ergonomic hand terminal
- Position of the control cabinet »freely selectable«

Automatic spindle clamping system

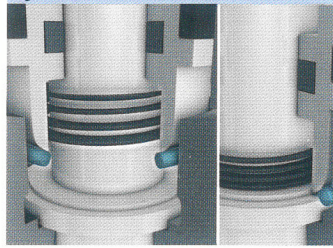

Patented system for exact drilling depth at any time with different materials

UPS

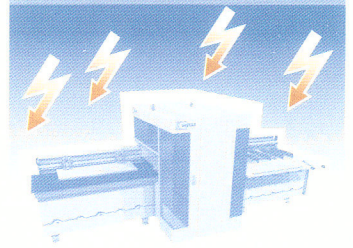

Protects the computer against damages in case of mains interruption

Large infeed area



- For optimization of the processing quality
- Secure workpiece guides for optimal processing quality

TBO-System®

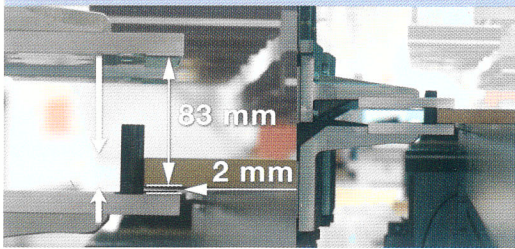

- No friction points
- Clamping devices clamp and release the workpiece from top AND bottom

Separated pressure beam

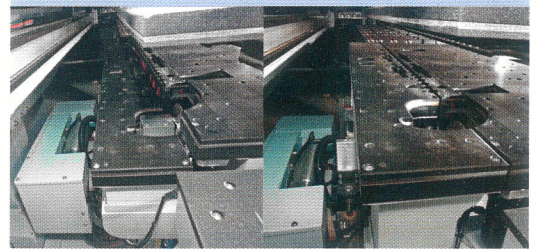

By lowering the front table part, the processing one the fixed side edge is easy and safe to handle.

WEEKE Quality Package - for long and strong reliability

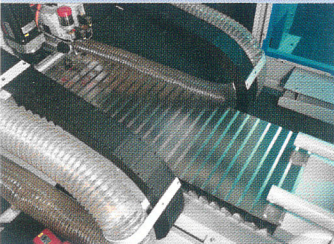

- Metallic bellow system → Perfect dust protection



- Sealed »long life« linear guiding system

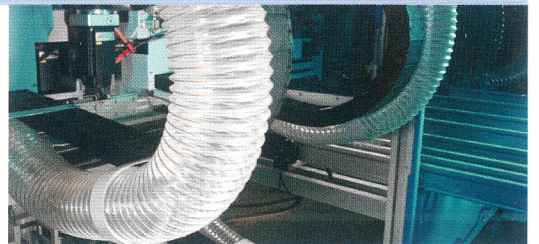

- Optimated dust extraction → minimisation of the dust emission
- Sealed cable guide

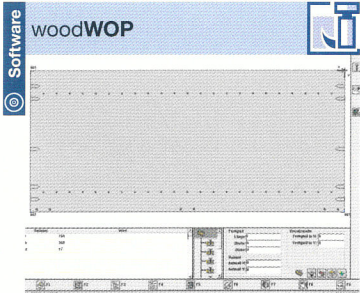

- Modern software based on Windows®
- More than 10.000 installations worldwide

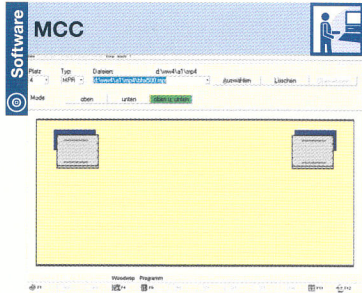

- Modern and simple control of main machine functions through soft keys
- Graphical loading
- Optimized space

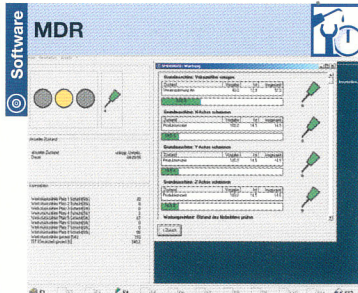

Machine Data Recording - collecting and evaluating machine states via time meter and event meter

Options

Workpiece up to 3000 mm

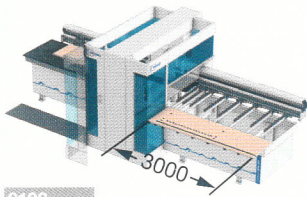

0103

Adjustment for workpiece processing up to 3000 mm in length

DXF-Postprocessor



The DXF format for the exchange of CAD drawings is used as the basis for woodWOP programs

Software

Barcode connection

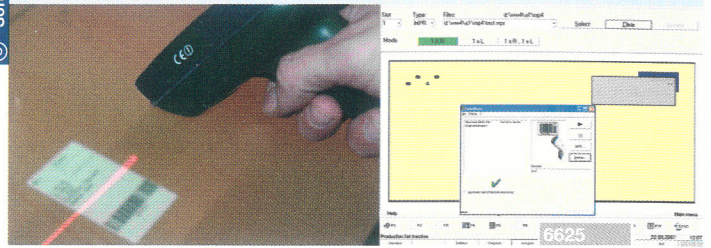

- Production list Interface-Software
- Printing software for easy processing of barcode labels

machine handling

Selectable operator side (right)

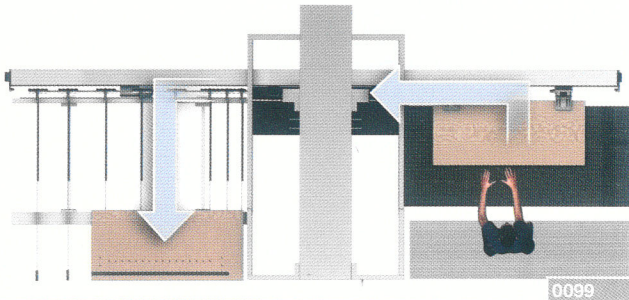

0099

Customer-specific adjustment of the operating side (standard left)

Infeed table with automatic workpiece feeding and positioning

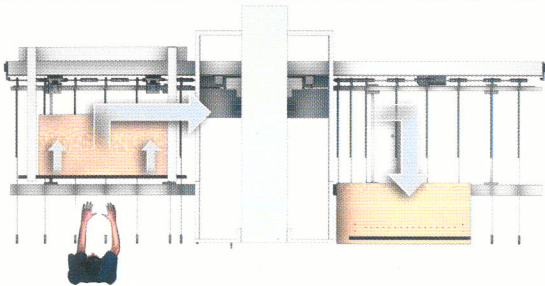

3407

Lengthwise infeed table with automatic workpiece feeding and positioning

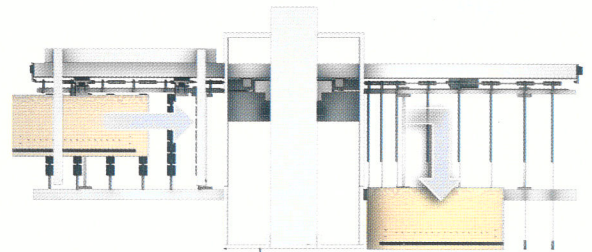

3409

Outfeed table with longitudinal length and/or cross outfeeding

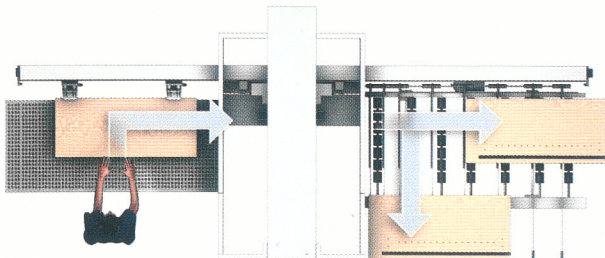

3412

Lengthwise outfeed table

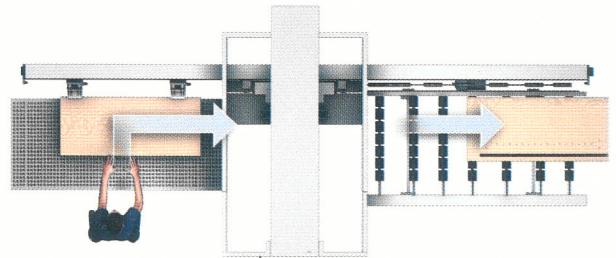

3413

Optimat BHX 500

Configuration 0025

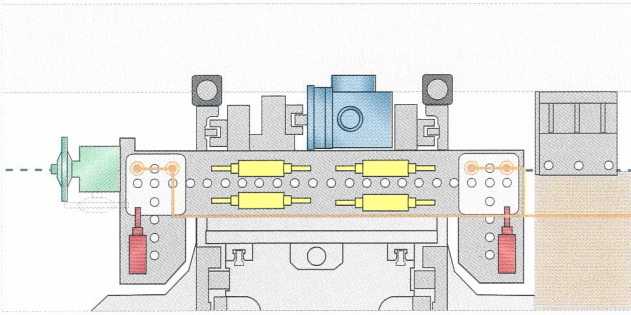

- 2 x 32 spindles
- 2 x 8 horizontal in X
- 2 x 2 horizontal spindles in Y
- 2 x swiveling grooving saw (90°)
- 2 x 6 kW ETP routing spindle

OPTION 3934:

additional packet: 2 x 4 vertical spindles

Configuration 0026

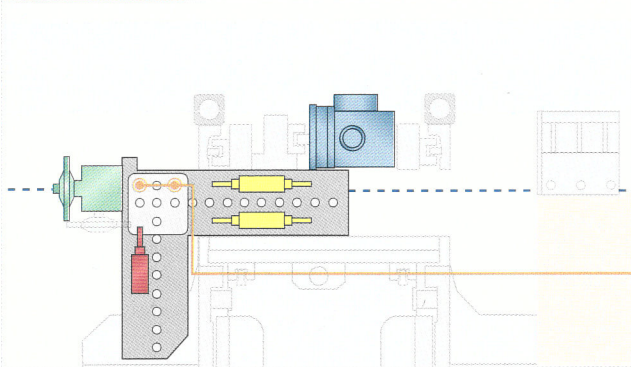

- 2 x 21 spindles
- 2 x 4 horizontal spindles in X
- 2 x 1 horizontal spindles in Y
- 2 x swiveling grooving saw (90°)
- 2 x 6 kW ETP routing spindle

OPTION 3936:

additional packet: 2 x 2 vertical spindles

Handling example with the Optimat ABD 100 and a vertical buffer

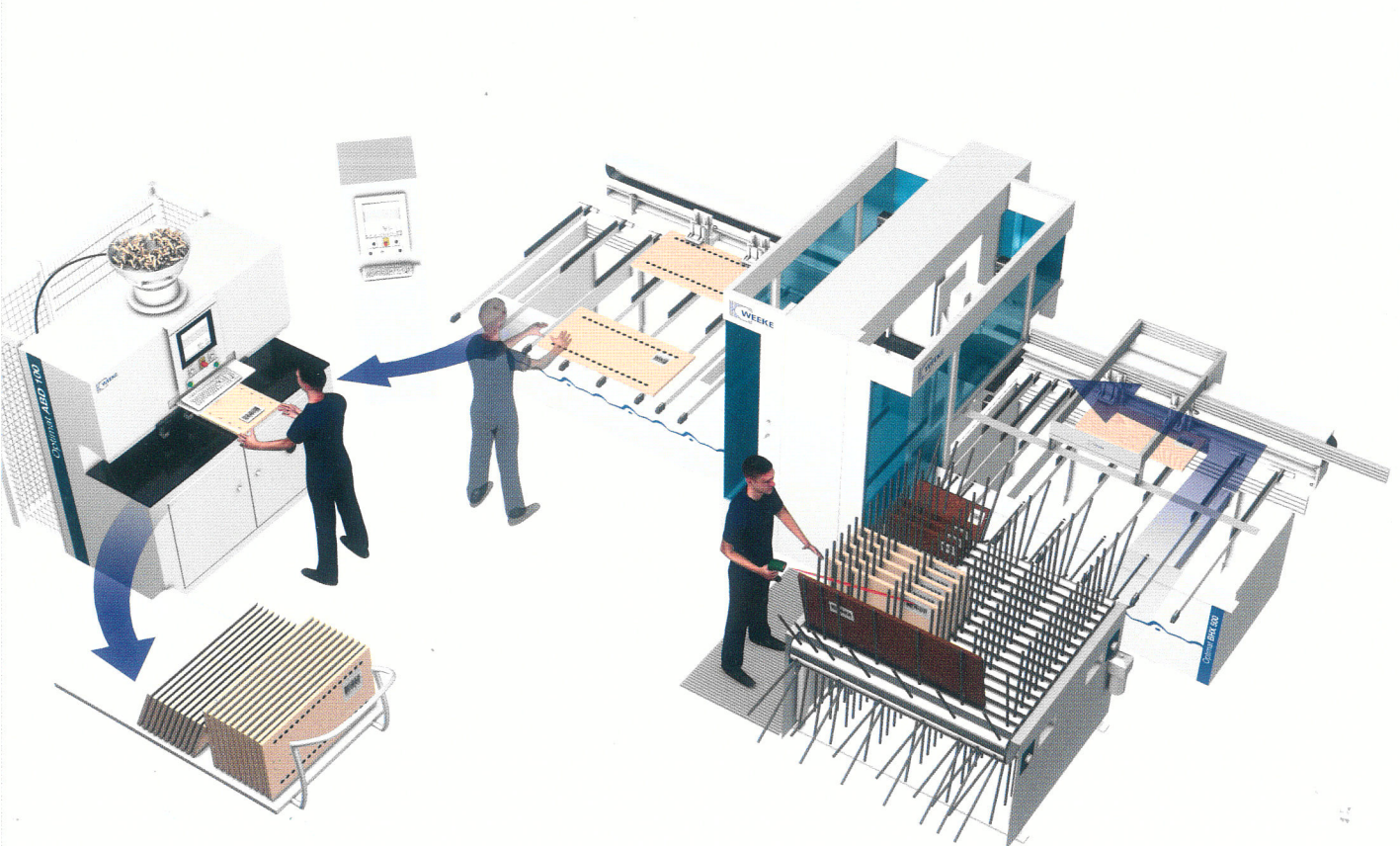

Dimensions

in mm

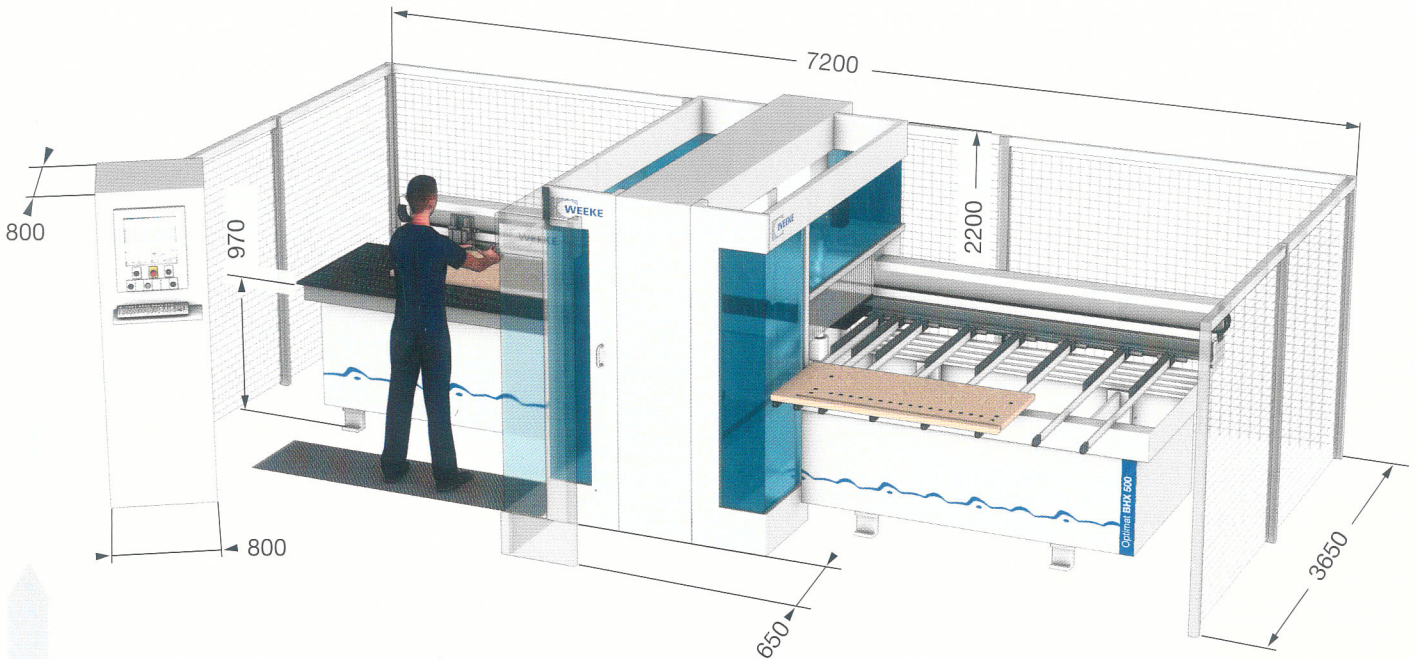

Position of the control cabinet »freely selectable«

Technical Data

Workpiece feeding dimensions	mm	2500 x 1300
Rapid traverse speed X - Y - Z-axis	m/min	138 - 80 - 50
Compressed air connection	inch	1"
Compressed air required	bar	7
Dust extraction port	mm	Ø 280
Dust extraction volume	m ³ /h	min. 5500
Total machine weight	kg	appr. 4500
Electrical power - total connection load	kW	19,5
Workpiece dimensions	mm	2500 x 1000

Contact us!



- Teleservice possibility via basic-internet-connection (TSN-possibility)
- Competent spare parts service
- Weeke Communication:
- Up-to-date information at all times: www.weeke.com
- Any questions, new ideas, criticism & praise to: info@weeke.de

Company of the Homag Group

Contact



WEEKE Bohrsysteme GmbH
Benzstraße 10-16
33442 HERZEBROCK-CLARHOLZ
 Germany
 Tel.: +49 5245 445-0
 Fax: +49 5245 445-139
info@weeke.de - www.weeke.de