

REV.	DESCRIPTION	REVISIONS	DATE	APPV
-	-	-	-	-

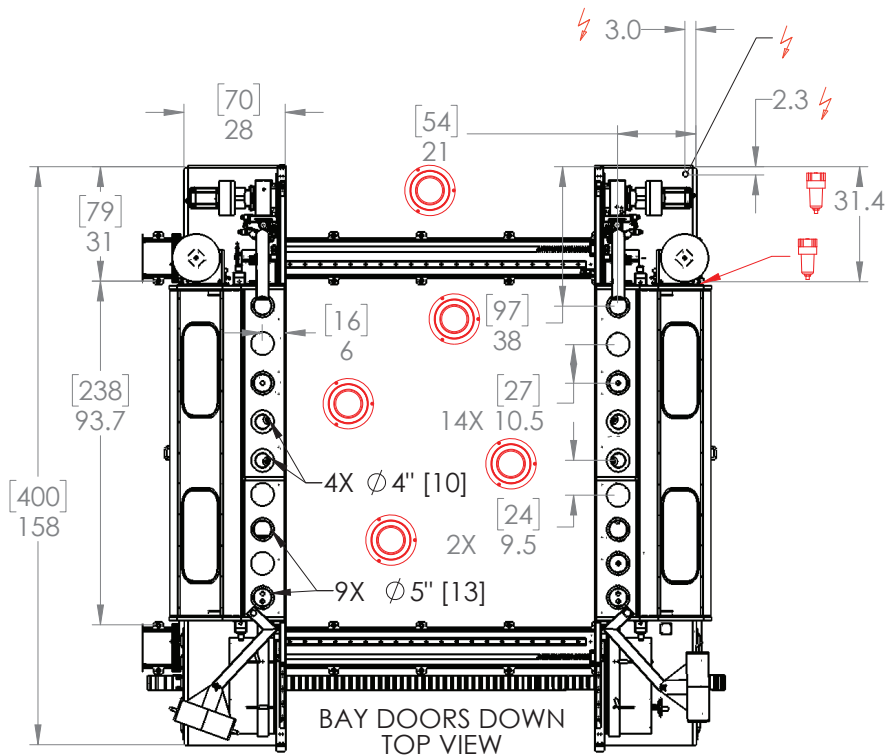
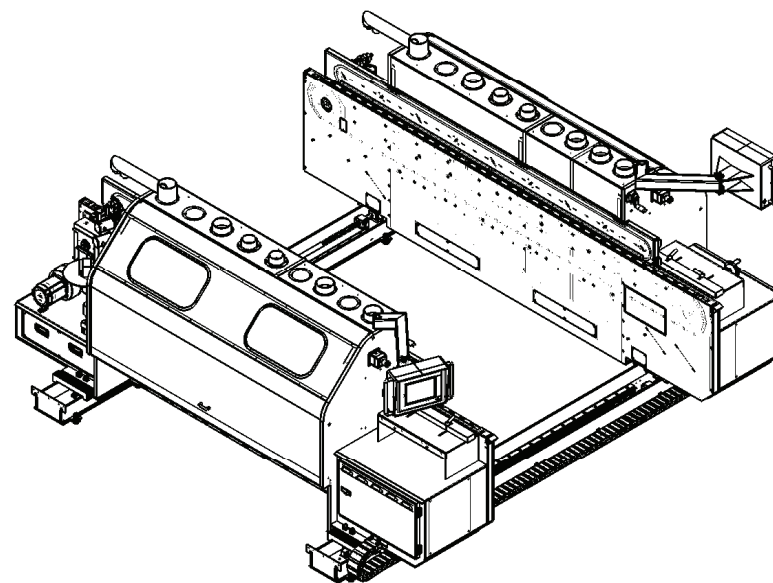
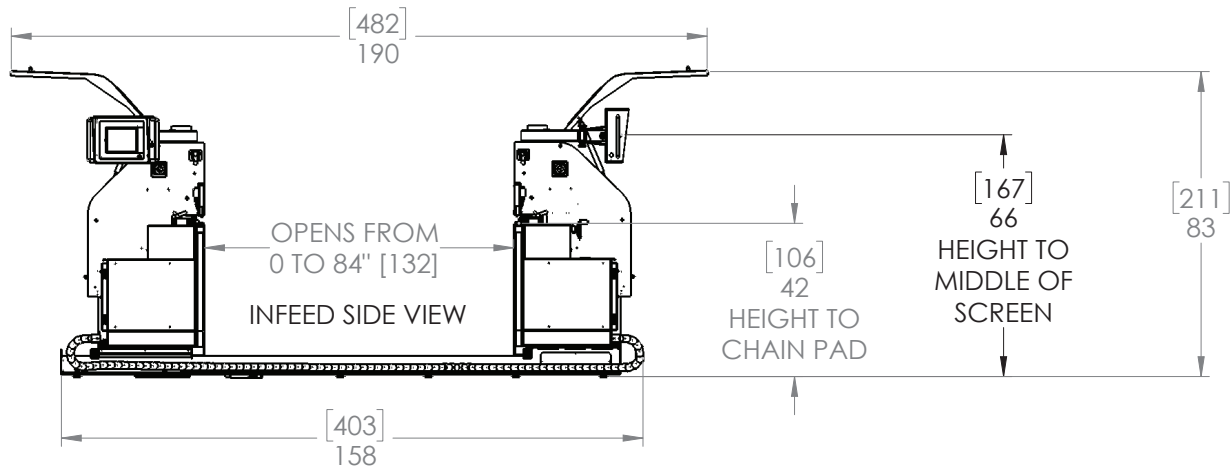

LEGEND

ELECTRICAL SERVICE REQUIRED:
 440-480 VAC, 3 PHASE, 50/60 HZ., 80 AMPS
 220-240 VAC, 3 PHASE, 50/60 HZ., 160 AMPS

PNEUMATIC SERVICE REQUIRED:
 80 PSIG, 5 SCFM.

DUST COLLECTION REQUIREMENTS:
 OUTLET DIAMETER: 9 @ Ø5 IN [13 CM];
 4 @ Ø4 IN [10 CM]
 VELOCITY: 4000 FPM [1220 MPM]
 VOLUME(13 PORTS): 3200 CFM [1500 LPS]

ELECTRICAL NOTES:

1. If voltage is less than 220 VAC, a Buckboost Transformer may be needed for optimum performance.
2. Main disconnect to be provided by others.
3. Field wiring must be copper wire rated at a minimum of 75°C

MOUNTING SCREW HOLES (LOCATED ON BASE):

Ø .75 [1.9] MOUNTING HOLES, 14 PER SIDE. (NOT ALL HOLES ARE REQUIRED TO MOUNT BASE TO FLOOR.)

NOTE:
 DIMENSIONS ARE INCHES WITH
 CENTIMETERS IN BRACKETS.

 BRILLIANT SOLUTIONS FOR WOOD	PROJECT:	
	CODE:	007337_La
	TYPE:	
	BRAND:	VOORWOOD L317N
	DESIGNER:	
	DATE:	
FILE:		