

machine supporting area
 concrete floor with 200 mm depth
 quality of concrete B25 (reinforced)
 suitable for straddling concrete
 The thickness of the concrete has to be at all
 pre-defined areas at least 200 mm! (including
 cut outs and pits for the scissor lift, tracks, etc.)

main connection
 connection value: 36 kW / 65A
 frequency: 50 Hz
 supply voltage: 400 V

required compressed air
 approx. 1600 l/min at 1 bar over-pressure
 air connection to machine min. 1"
 min. pressure 6 bar

POTENTIAL BONDING EN1 / Part 1
 earth conductor (equipotential bonding,
 better 2 Ohm ideal 1-1.2 Ohm)

dust extraction
 2x dust extraction ϕ 120 at angular fence
 2230mm over floor
 1x dust extraction ϕ 150 165mm over floor
 1x dust extraction ϕ 80 110mm over floor
 extraction requirements 5300 m³/h
 at 32 m/s air speed
 under pressure: 3000 pascal at saw machine
 change of saw blade

customers responsibilities
 providence of all foundations,
 safety rails and connections of power,
 compressed air and dust collectors.

IMPORTANT !
 We kindly ask you to check this drawing carefully.
 If we do not receive any written comment within 3 weeks
 from the date of drawing dispatch, we will consider
 this drawing as accepted.

Schelling Anlagenbau GmbH
 Neuschwanberg
 z.N. Rosenau
 GMBH - Schwarzenaustr. 34
 6858 SCHWARZENAU
 AUSTRIA

All dimensions in mm !
 Please find further information
 in the acknowledgement of order !

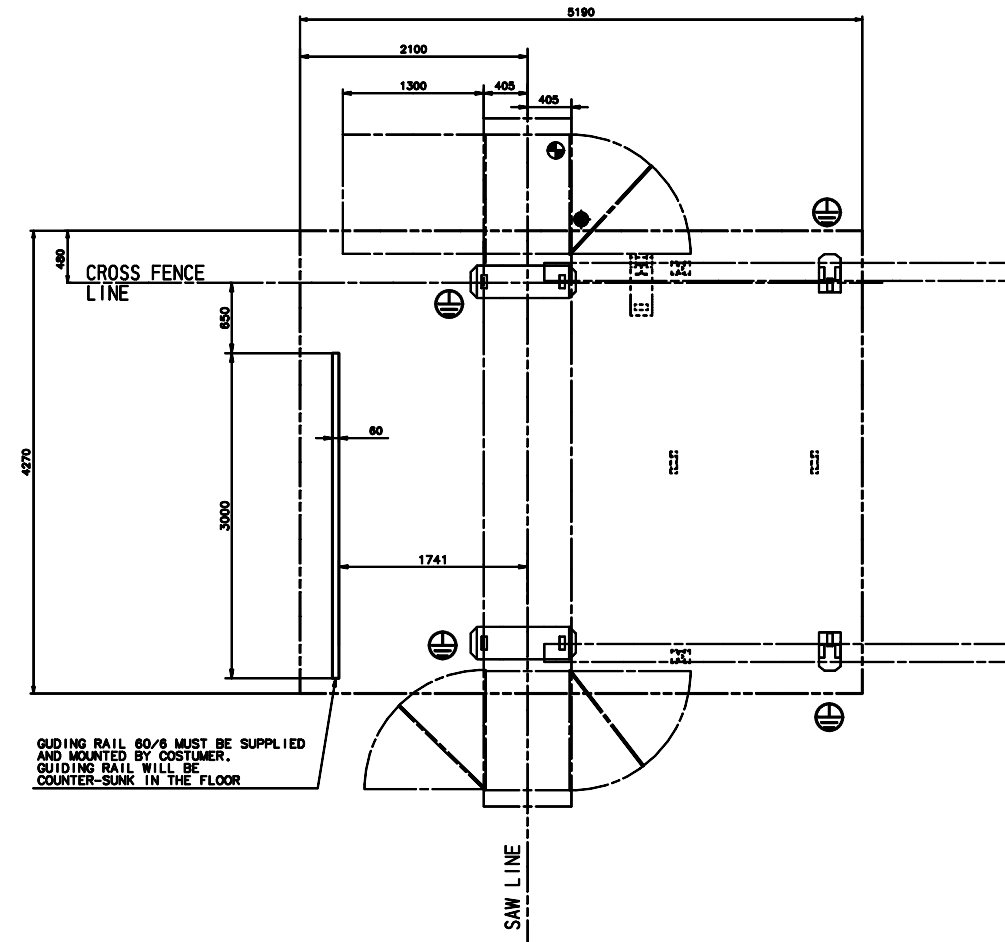
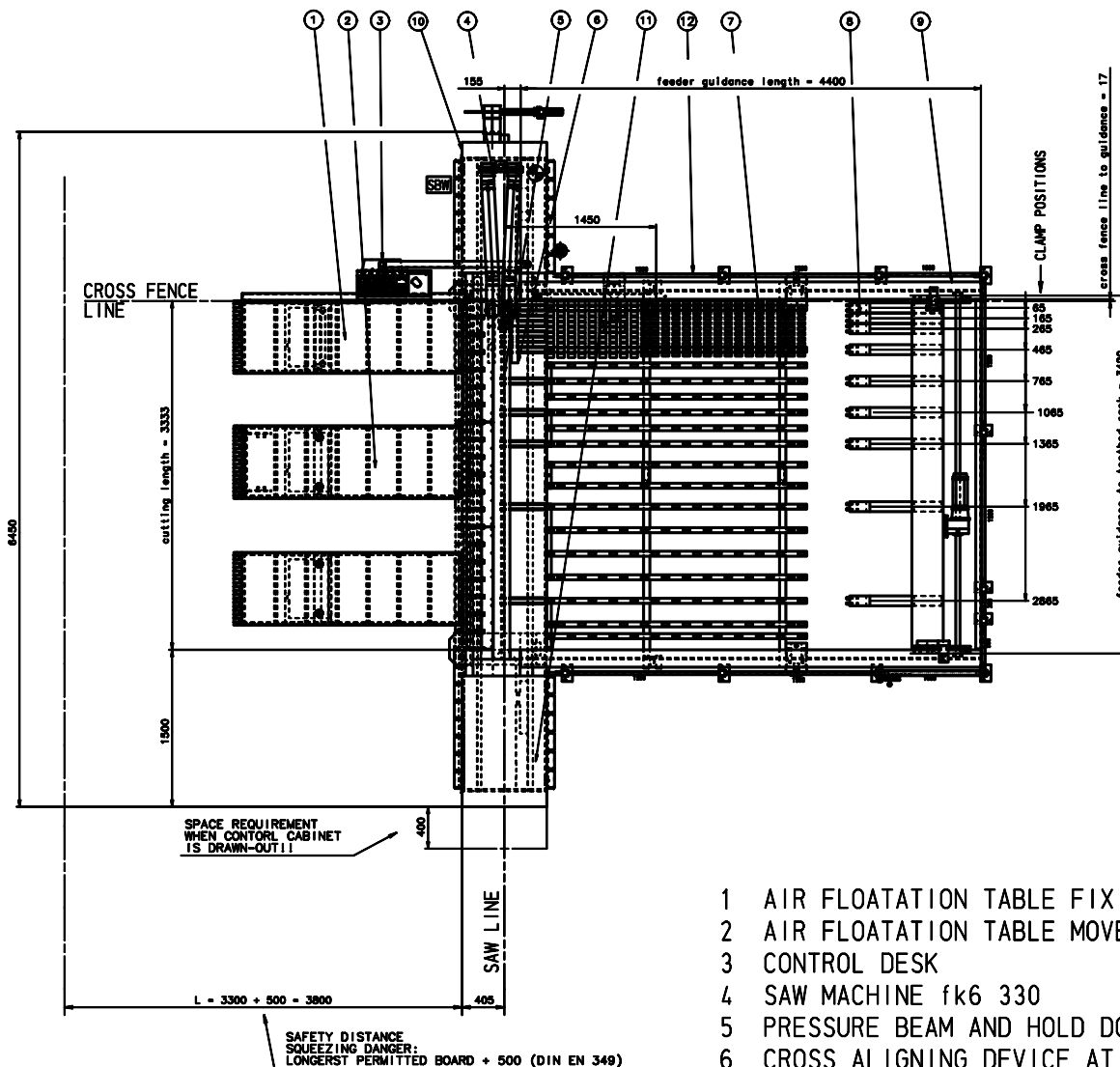

- 1 AIR FLOATATION TABLE FIX
- 2 AIR FLOATATION TABLE MOVEABLE
- 3 CONTROL DESK
- 4 SAW MACHINE fk6 330
- 5 PRESSURE BEAM AND HOLD DOWN BEAM
- 6 CROSS ALIGNING DEVICE AT PRESSURE BEAM
- 7 ROLLER TABLE
- 8 FEEDER WITH CLAMPS
- 9 FEEDER TRAVELING GUIDE
- 10 CONTROL CABINET 1
- 11 CONTROL CABINET 2
- 12 PROTECTION GRID

Disegnatore: Ferwood srl		<p>BRILLIANT SOLUTIONS FOR WOOD</p> <p>FerWood srl - Via Langhe 4/A 12042 Pollenzo (CN) Italy Tel: +39 0172 474073 - fax: +39 0172 471642 email: info@ferwoodgroup.com</p>
Titolo: 005490_MA		
Descrizione: Beam Saw Machine SCHELLING FK6 330/3300		<p>Versione 1</p> <p>Data: Sistema: Foglio: A3</p>
Versione 1		
Data:		
Data:		
Tutti i diritti sono riservati da Copyright vietata la riproduzione ALL rights reserved by Copyright is forbidden to reproduce		