

# Nested Based CNC-Router Vantech 480 | 510 | 512 | 612

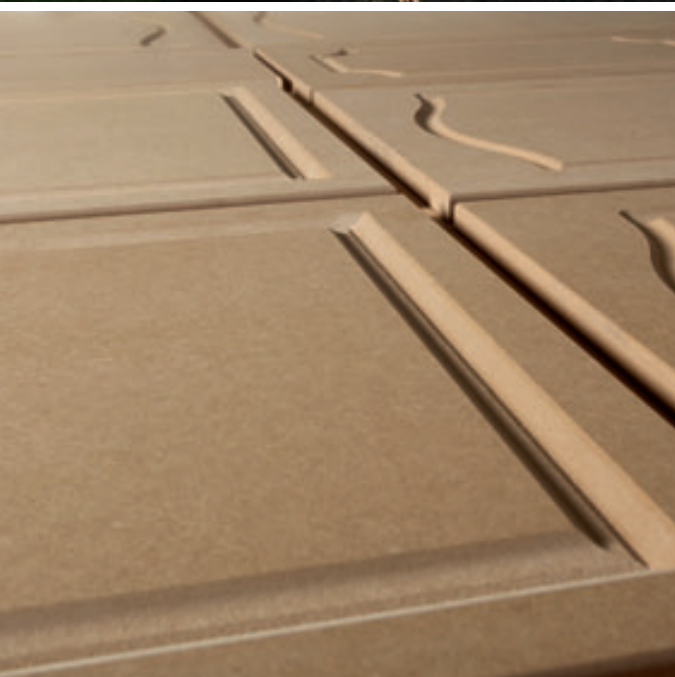

# Vantech 480 | 510 | 512 | 612

Nesting technology means to „nest“ workpieces in order to achieve optimum material utilization by using cutting optimization. Nesting offers the opportunity to significantly improve yield particularly when processing a large variety of shaped parts.



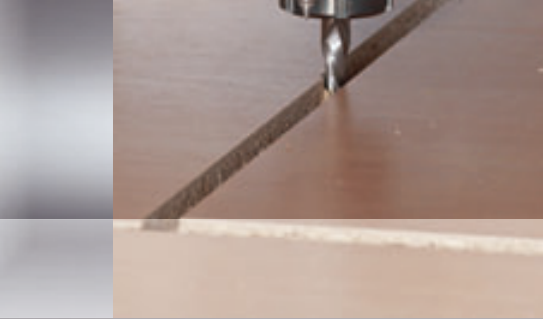

# The magic always lies in the detail...

Theodor Fontane



## Content

- 4 Basic Machine
- 6 Handling Concept Outfeed
- 8 Handling Concept 1
- 10 Handling Concept 2
- 12 Handling Concept 2R
- 14 Handling Concept 3 labelling
- 16 Handling Concept 3R labelling
- 18 Vacuum Zones
- 19 Manual & Automatic Concepts
- 22 Nesting with storage
- 24 Options
- 26 Hardware | Software
- 28 **powerTouch**
- 30 Nesting Software
- 32 Technical data

# Basic Machine

BASIC  
PACKAGE

FUTURE  
PACKAGE

PERFORMANCE  
PACKAGE



## Choose your system in two easy steps:

# 1

### First: Choose your automation level

<b>A</b>	Basic Machine (BM)	=	stand alone   Concept BASIC HANDLING
<b>B</b>	BM with Outfeeding	=	finished parts moved out automatically   Concept Outfeed
<b>C</b>	BM with Infeeding + Outfeeding	=	full board moved in automatically and finished parts moved out automatically   Concept 1   Concept 2
<b>D</b>	BM with Infeeding + Labelling + Outfeeding	=	full board moved in automatically and be labelled (e.g. barcode) and finished parts moved out automatically   Concept 3

detailed Concept overview on page 20/21

# 2

### Secondly: Choose your power processing level:

<b>I.</b>	BASIC PACKAGE	=	compatibel with <b>A</b>
<b>II.</b>	FUTURE PACKAGE	=	compatibel with <b>A   B   C   D</b>
<b>III.</b>	PERFORMANCE PACKAGE	=	compatibel with <b>A   B   C   D</b>

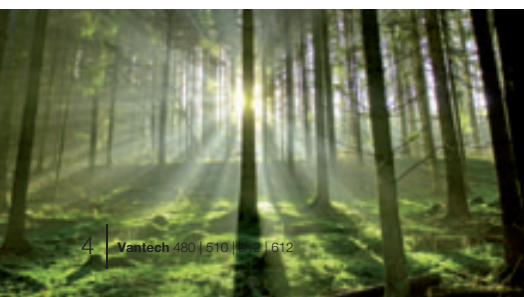

# Choose your power processing level:

## BASIC PACKAGE

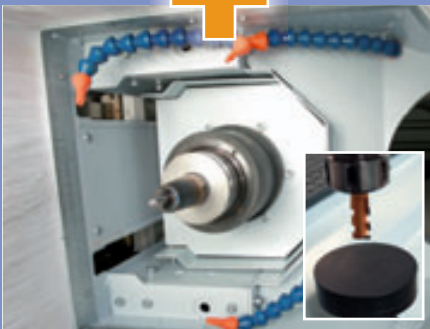

- 7 vertical drilling spindles
- Tool changing system with tool pick-up station  
(480: 7 pick-up places / 510-512: 8 and 612: 9 pick-up places)
- 13 HP (10 kW) HSK 63 routing spindle or 18 HP (13,2 kW) HSK 63 routing spindle with Air Jet Technology
- Tool length control

## FUTURE PACKAGE

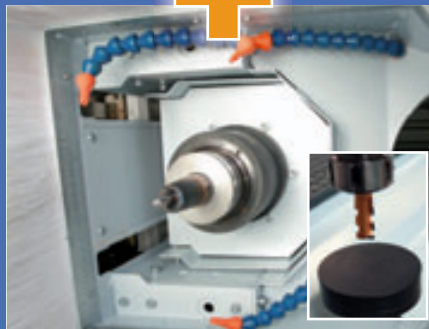

- 7 vertical drilling spindles
- 13-fold tool changer disc-type pick-up
- 13 HP (10 kW) HSK 63 routing spindle or 18 HP (13,2 kW) HSK 63 routing spindle with Air Jet Technology
- Tool length control

## PERFORMANCE PACKAGE

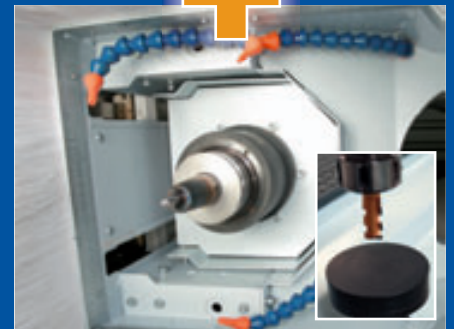

- 12 vertical drilling spindles
- 13-fold tool changer disc-type pick-up
- 13 HP (10 kW) HSK 63 routing spindle or 18 HP (13,2 kW) HSK 63 routing spindle with Air Jet Technology
- Tool length control

Equipment as described in this brochure is subject to technical changes and further developments. Technical data refer to standard equipment and are not binding for the order.

# Handling Concept Outfeed

Basic Machine

+ Outfeed

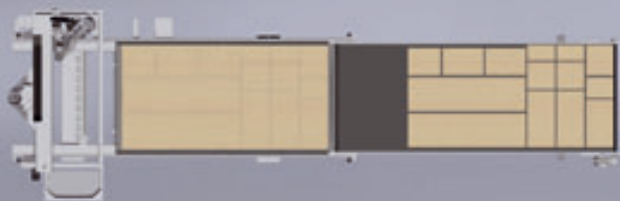

## Synchronous drive

- 2 synchronized X-drives guarantee highest processing quality
- 96 m/min vector speed

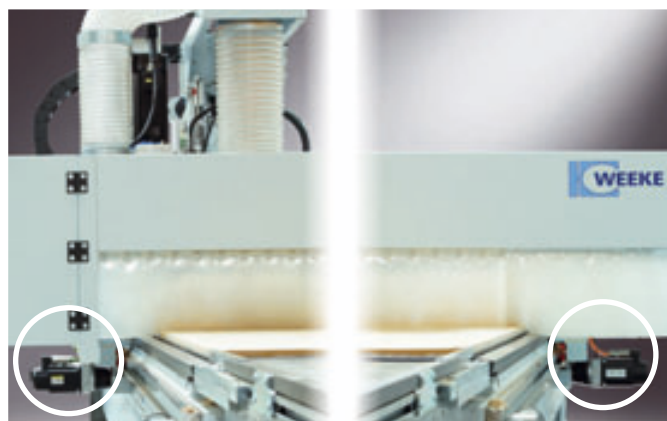

## powerControl with powerTouch

- 21,5" Full-HD multitouch display with wide screen 16:9
- Front USB interface
- Ethernet connection 10/100 Mbit

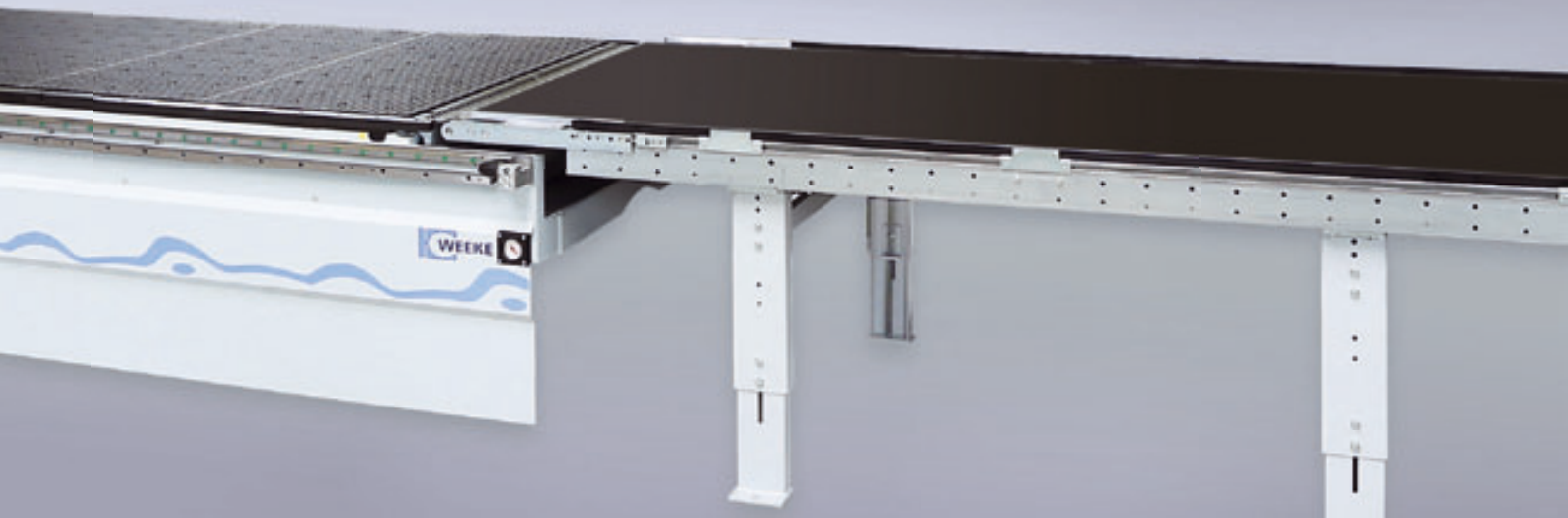

**Dust extraction channel at the outfeed from below**

- For cleaning of the workpieces during feeding out



**Transport belt**

- A workpiece safety control device is attached at the end of the conveyor belt, this stop function can be deactivated via a foot switch

**Lowerable fence guide and program-controlled positioning**

- Suitable for safe outfeed of workpieces
- Electr. surveillance of all guides and stops

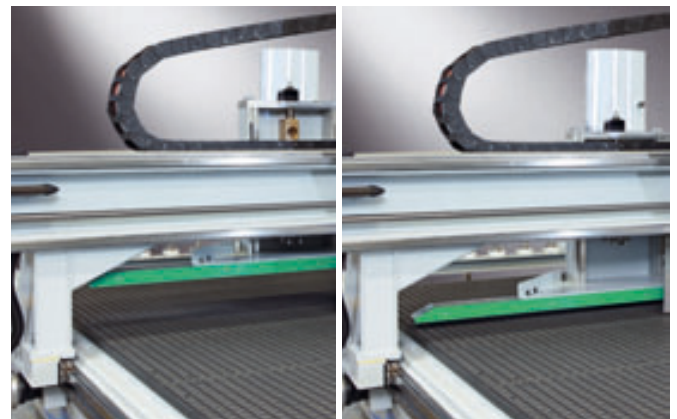
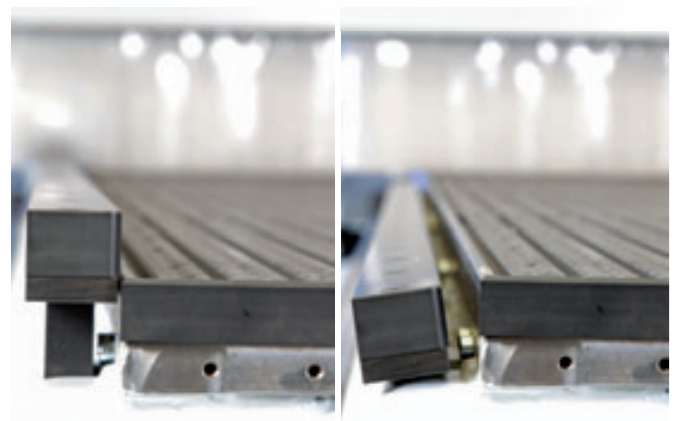

**Push-off device**

- Automatic push-off device, mounted to the gantry, for pushing off workpieces and dust extraction for cleaning cover board

Equipment as described in this brochure is subject to technical changes and further developments. Technical data refer to standard equipment and are not binding for the order.

# Handling Concept 1

## Basic Machine

- + Infeed (Customer)
- + Outfeed



## Transfer rollers

- Intermediary transfer rollers to prevent scratching during the loading process



## Vacuum arm for positioning

- The vacuum arm takes over a pre-positioned raw board and aligns this against the end of the table in X direction

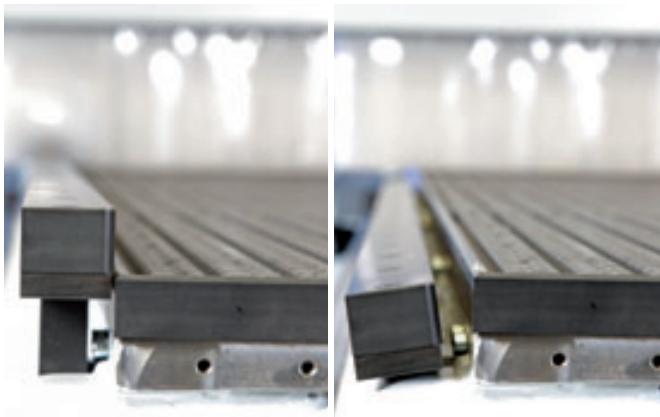

## Lowerable fence guide and program-controlled positioning

- Suitable for safe outfeed of workpieces
- Electr. surveillance of all guides and stops

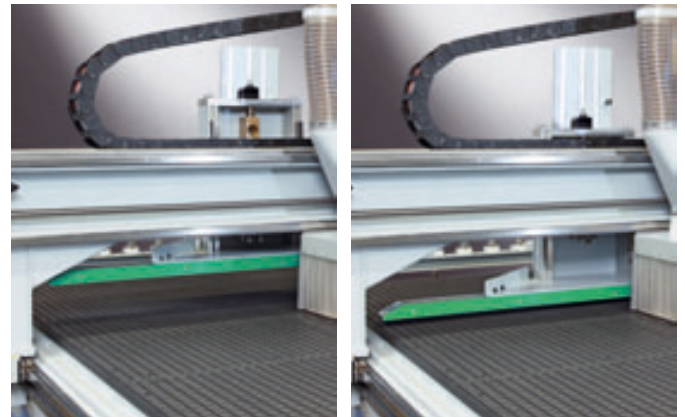

## Push-off device

- Automatic push-off device, mounted to the gantry, for pushing off workpieces and dust extraction for cleaning cover board



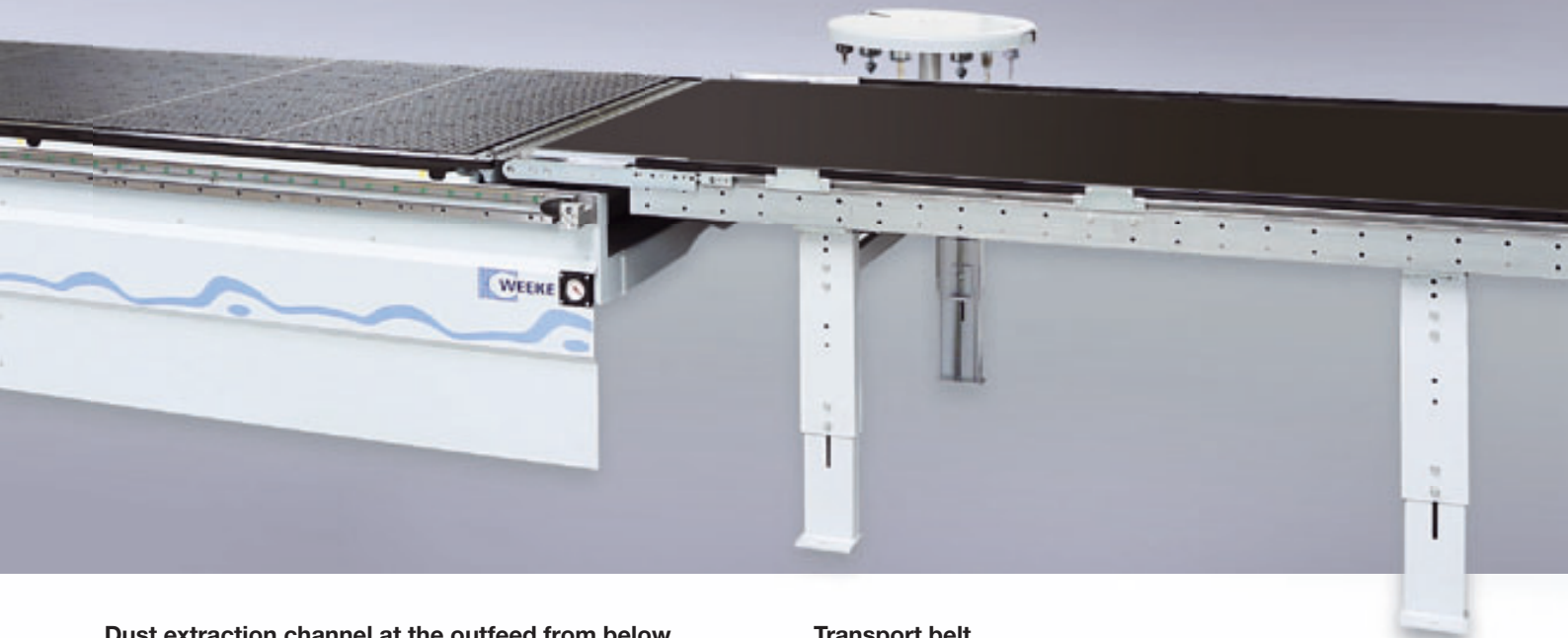

#### Dust extraction channel at the outfeed from below

- For cleaning of the workpieces during feeding out



#### Transport belt

- A workpiece safety control device is attached at the end of the conveyor belt, this stop function can be deactivated via a foot switch

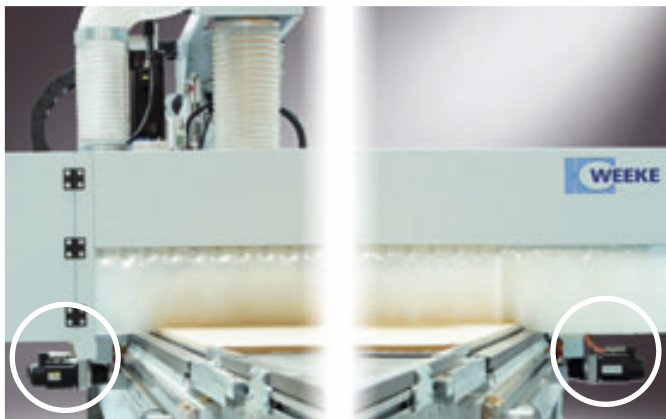

#### Synchronous drive

- 2 synchronized X-drives guarantee highest processing quality
- 96 m/min vector speed



#### powerControl with powerTouch

- 21,5" Full-HD multitouch display with wide screen 16:9
- Front USB interface
- Ethernet connection 10/100 Mbit

Equipment as described in this brochure is subject to technical changes and further developments. Technical data refer to standard equipment and are not binding for the order.

# Handling Concept 2

## Basic Machine

- + Infeed (lifting table)
- + Outfeed

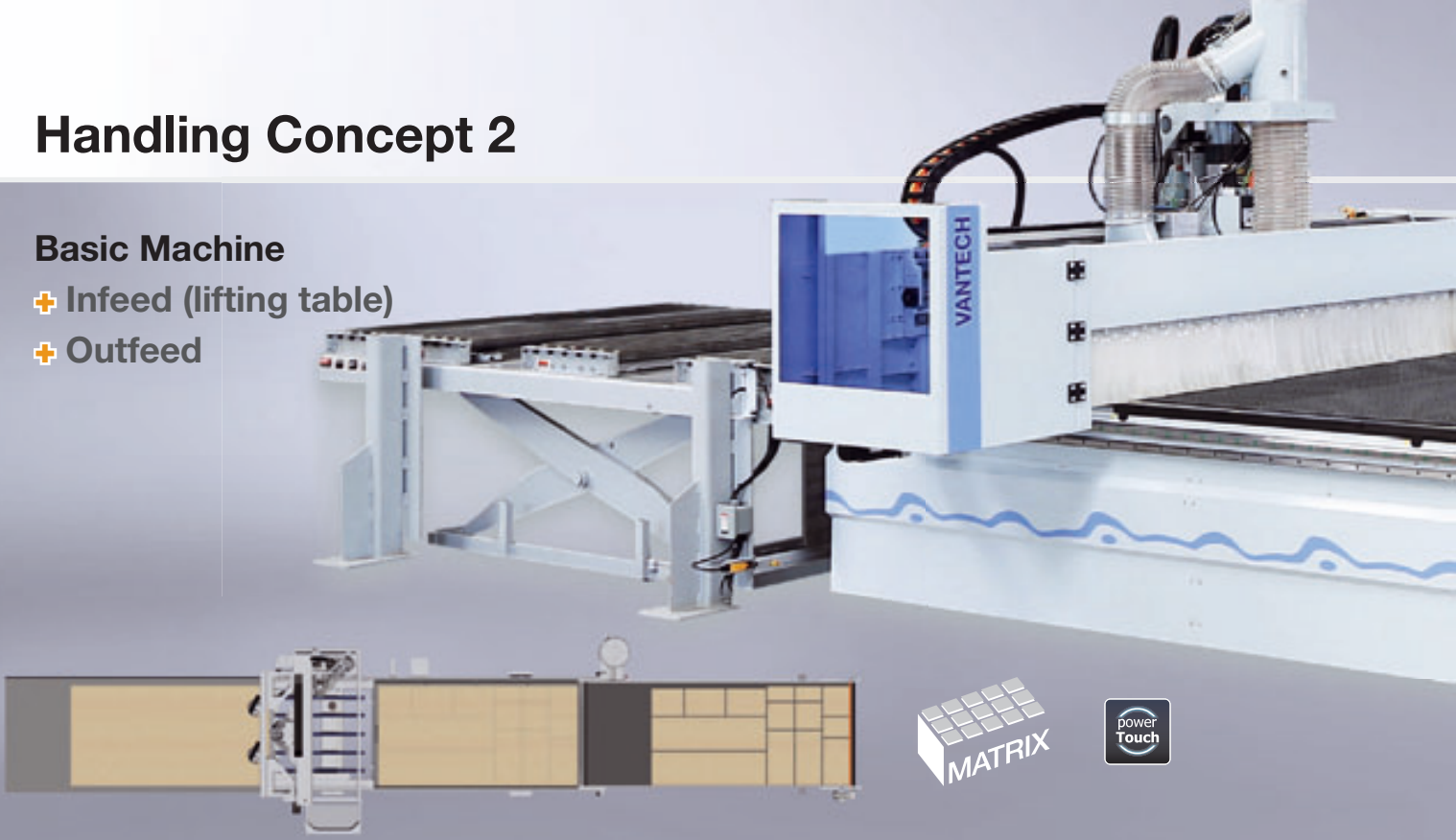

### Lifting table

- For easy infeeding

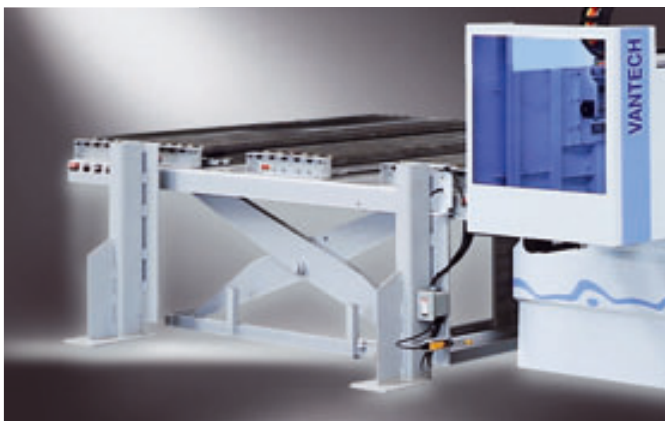

### Transfer rollers

- Intermediary transfer rollers to prevent scratching during the loading process



### Vacuum arm for positioning

- The vacuum arm takes over a pre-positioned raw board and aligns this against the end of the table in X direction

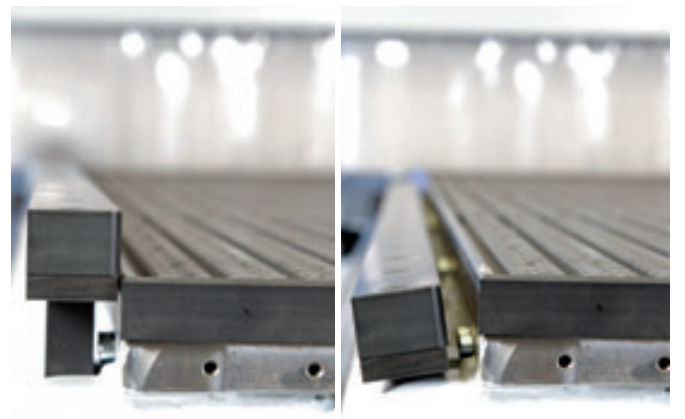

### Lowerable fence guide and program-controlled positioning

- Suitable for safe outfeed of workpieces
- Electr. surveillance of all guides and stops

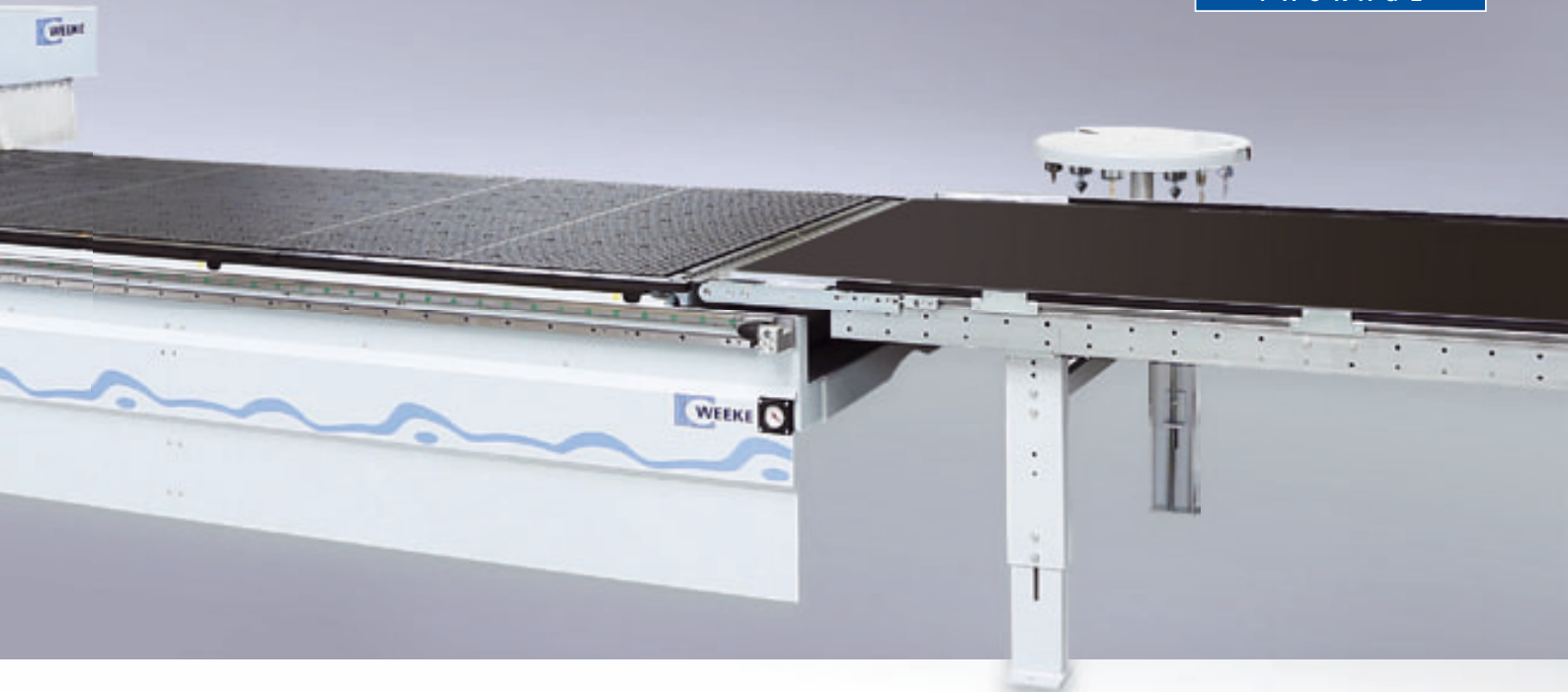

#### Push-off device

- Automatic push-off device, mounted to the gantry, for pushing off workpieces and dust extraction for cleaning cover board

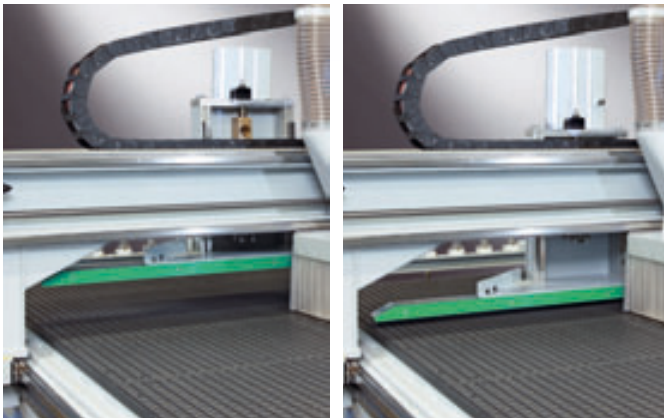

#### Dust extraction channel at the outfeed from below

- For cleaning of the workpieces during feeding out



#### Transport belt

- A workpiece safety control device is attached at the end of the conveyor belt, this stop function can be deactivated via a foot switch



#### powerControl with powerTouch

- 21,5" Full-HD multitouch display with wide screen 16:9
- Front USB interface
- Ethernet connection 10/100 Mbit

Equipment as described in this brochure is subject to technical changes and further developments. Technical data refer to standard equipment and are not binding for the order.

# Handling Concept 2R

## Basic Machine

- + Infeed (roller table)
- + Outfeed

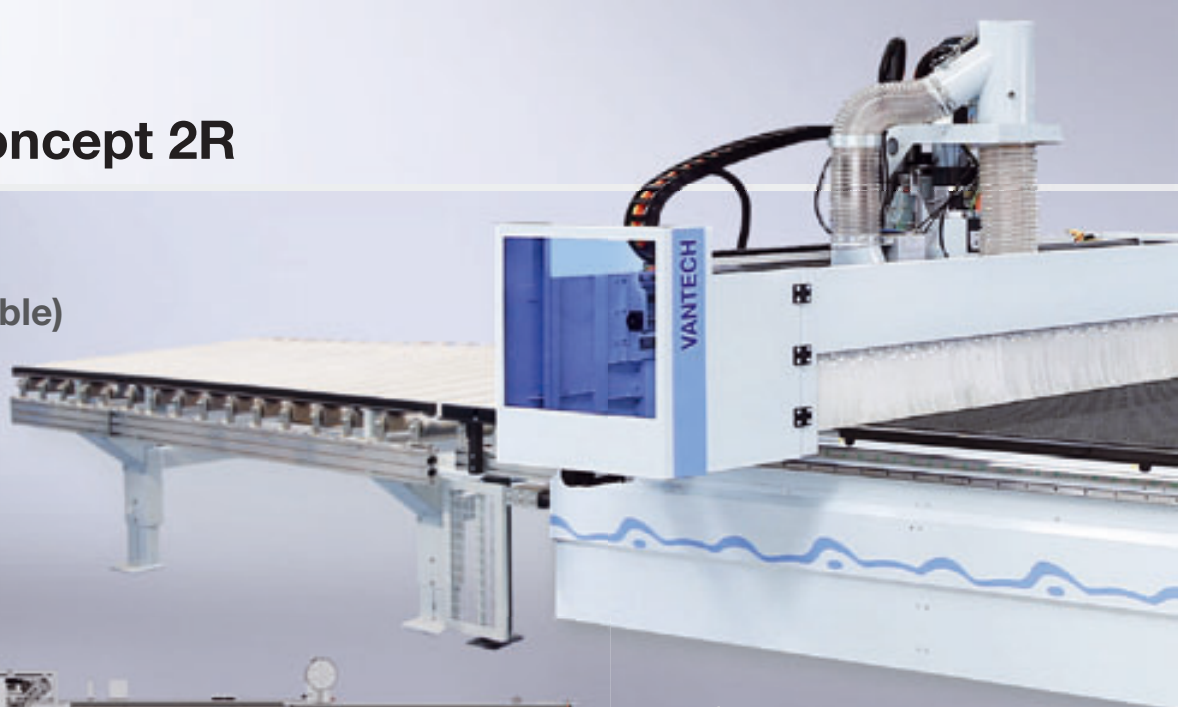

### Infeed table

- Frequency-controlled roller table



### Transfer rollers

- Intermediary transfer rollers to prevent scratching during the loading process



### Vacuum arm for positioning

- The vacuum arm takes over a pre-positioned raw board and aligns this against the end of the table in X direction

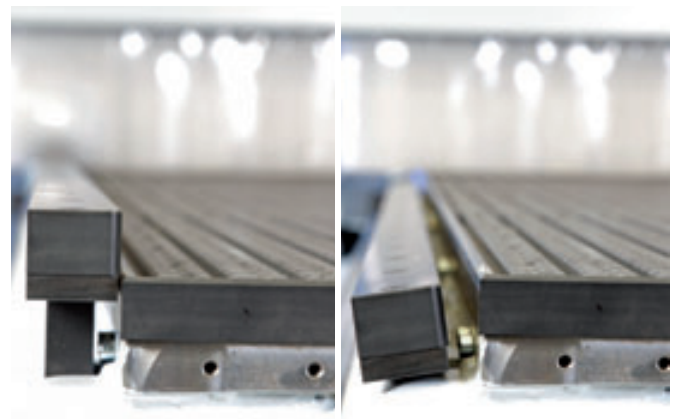

### Lowerable fence guide and program-controlled positioning

- Suitable for safe outfeed of workpieces
- Electr. surveillance of all guides and stops



#### Push-off device

- Automatic push-off device, mounted to the gantry, for pushing off workpieces and dust extraction for cleaning cover board

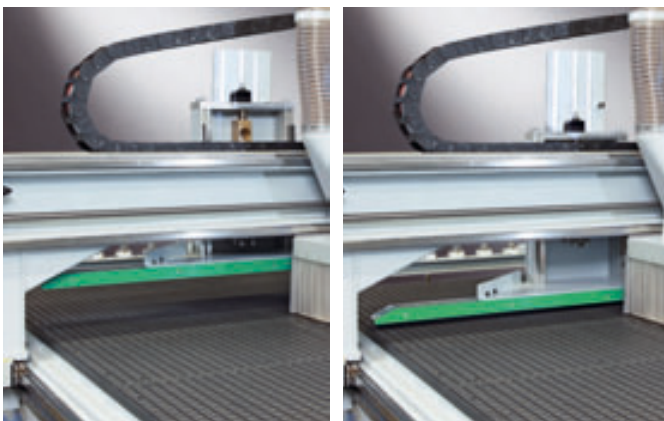

#### Dust extraction channel at the outfeed from below

- For cleaning of the workpieces during feeding out



#### Transport belt

- A workpiece safety control device is attached at the end of the conveyor belt, this stop function can be deactivated via a foot switch



#### powerControl with powerTouch

- 21,5" Full-HD multitouch display with wide screen 16:9
- Front USB interface
- Ethernet connection 10/100 Mbit

Equipment as described in this brochure is subject to technical changes and further developments. Technical data refer to standard equipment and are not binding for the order.

# Handling Concept 3

## Basic Machine

- + Infeed (lifting table)
- + Outfeed
- + Labelling

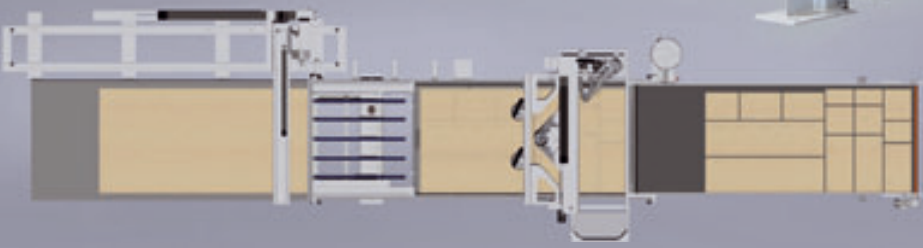

### Barcode printer / Lifting table

- Automatic Label Printing for precise handling and identification of the workpieces



### Transfer rollers

- Intermediary transfer rollers to prevent scratching during the loading process



### Vacuum arm for positioning

- The vacuum arm takes over a pre-positioned raw board and aligns this against the end of the table in X direction

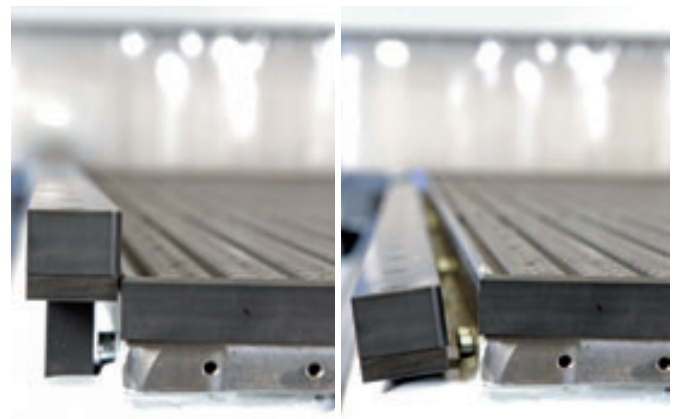

### Lowerable fence guide and program-controlled positioning

- Suitable for safe outfeed of workpieces
- Electr. surveillance of all guides and stops



#### Push-off device

- Automatic push-off device, mounted to the gantry, for pushing off workpieces and dust extraction for cleaning cover board

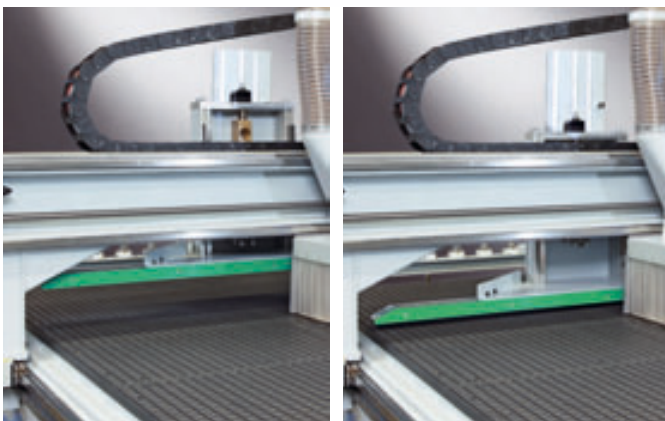

#### Dust extraction channel at the outfeed from below

- For cleaning of the workpieces during feeding out



#### Transport belt

- A workpiece safety control device is attached at the end of the conveyor belt, this stop function can be deactivated via a foot switch



#### powerControl with powerTouch

- 21,5" Full-HD multitouch display with wide screen 16:9
- Front USB interface
- Ethernet connection 10/100 Mbit

Equipment as described in this brochure is subject to technical changes and further developments. Technical data refer to standard equipment and are not binding for the order.

# Handling Concept 3R

## Basic Machine

- + Infeed (roller table)
- + Outfeed
- + Labelling

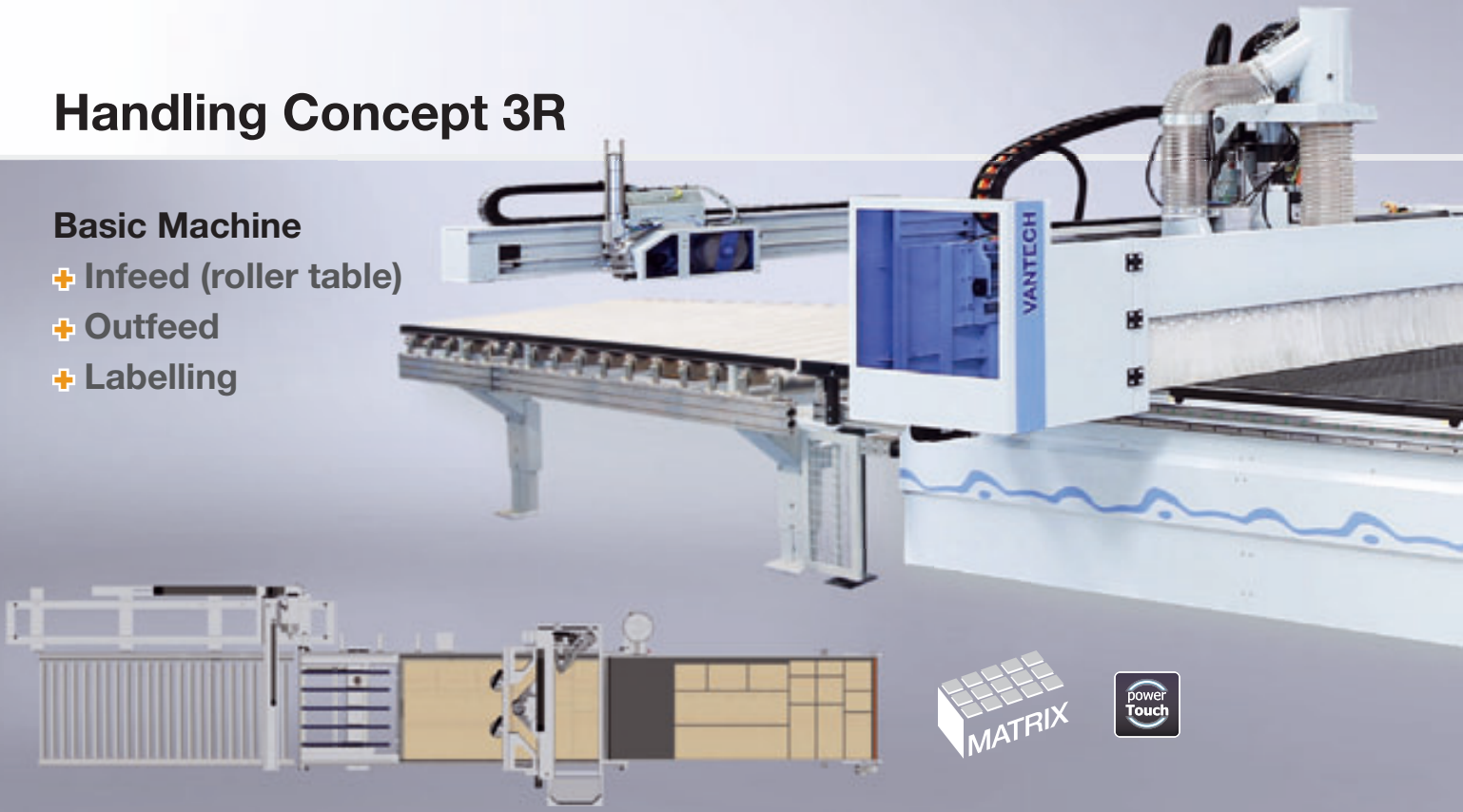

## Barcode printer / Lifting table

- Automatic Label Printing for precise handling and identification of the workpieces

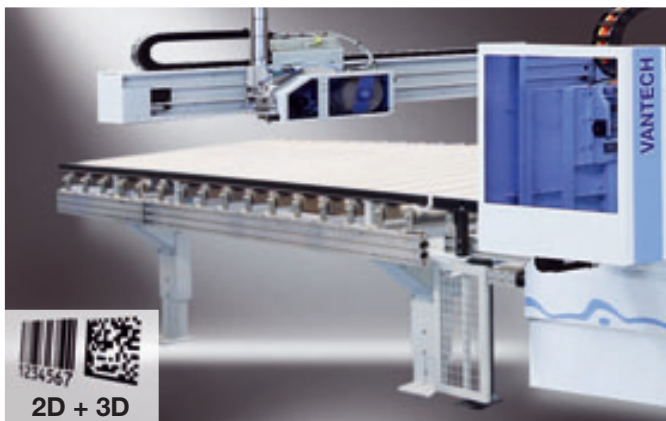

## Transfer rollers

- Intermediary transfer rollers to prevent scratching during the loading process



## Vacuum arm for positioning

- The vacuum arm takes over a pre-positioned raw board and aligns this against the end of the table in X direction

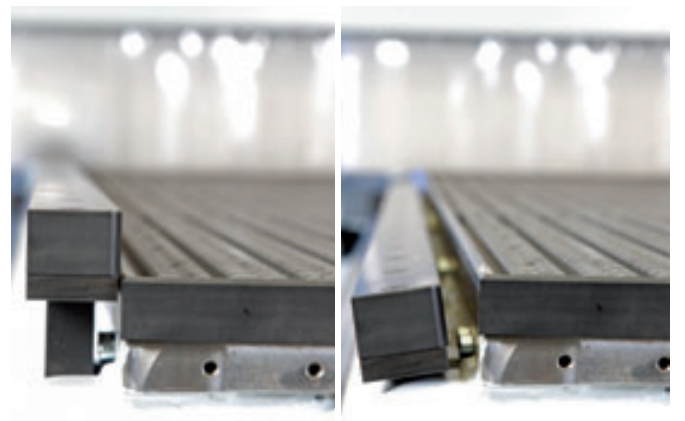

## Lowerable fence guide and program-controlled positioning

- Suitable for safe outfeed of workpieces
- Electr. surveillance of all guides and stops



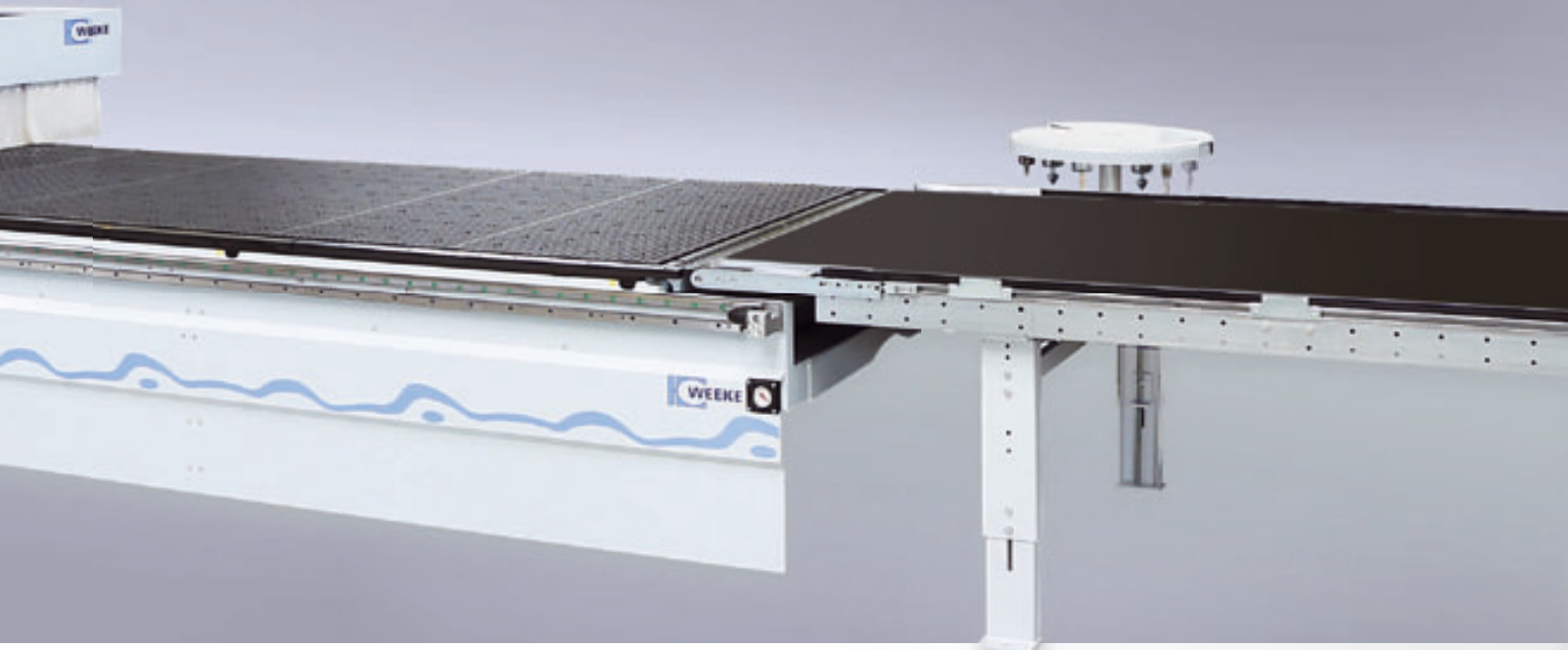

#### Push-off device

- Automatic push-off device, mounted to the gantry, for pushing off workpieces and dust extraction for cleaning cover board

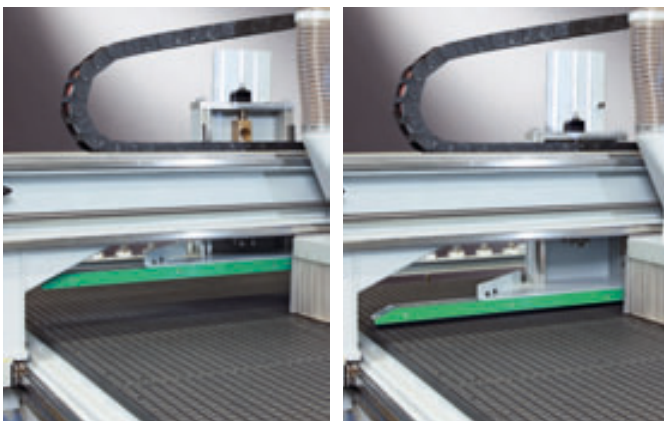

#### Dust extraction channel at the outfeed from below

- For cleaning of the workpieces during feeding out



#### Transport belt

- A workpiece safety control device is attached at the end of the conveyor belt, this stop function can be deactivated via a foot switch



#### powerControl with powerTouch

- 21,5" Full-HD multitouch display with wide screen 16:9
- Front USB interface
- Ethernet connection 10/100 Mbit

Equipment as described in this brochure is subject to technical changes and further developments. Technical data refer to standard equipment and are not binding for the order.

# Vantech 480 | 510 | 512 | 612

Nesting machines are utilized across a wide variety of market segments. We see nested based manufacturing strategies employed in the production of cabinetry, doors and drawers, closets and storage, furniture, store fixtures, work surfaces, plastics and composites, non-ferrous metals, as well as aerospace.

The Vantech PRO+ MATRIX Table system is perfectly suited to handle the raw material variance noted by some of today's multi-faceted manufacturers. The solution reads the raw board size of the incoming program and automatically concentrates vacuum pressure to the correct area of the machine, limiting machine setup time. Vacuum zones can also be manually selected at the machine control.

## 480 Matrix Pro

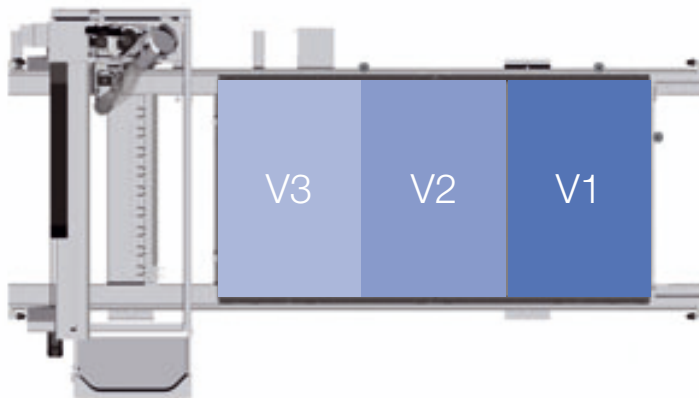

### Matrix-Table PRO for Vantech 480 (1250 x 2500 mm)

3 zones controlled by softkey at the machine control

V1 = 2.6 x 4 ft  
 V1+V2 = 5.2 x 4 ft  
 V1+V2+V3 = 8.2 x 4 ft

## 510 Matrix Pro +

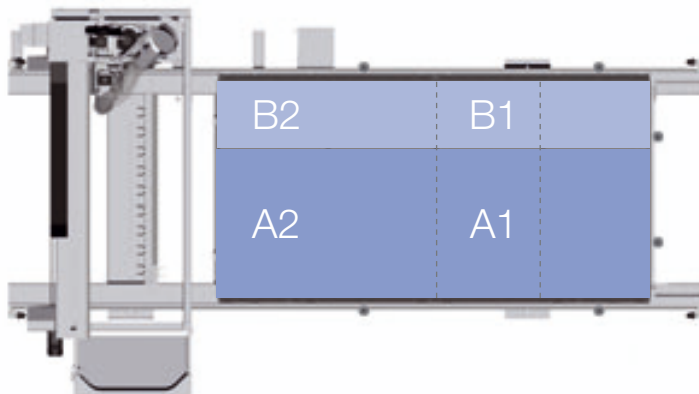

### Matrix-Table PRO+ for Vantech 510 (1550 x 3100 mm)

8 automatically controlled vacuum fields for boards with dimensions such as:

A1 = 8 x 4 ft  
 A1+A2 = 10 x 4 ft  
 A1+B1 = 8 x 5 ft  
 A1+A2+B1+B2 = 10 x 5 ft

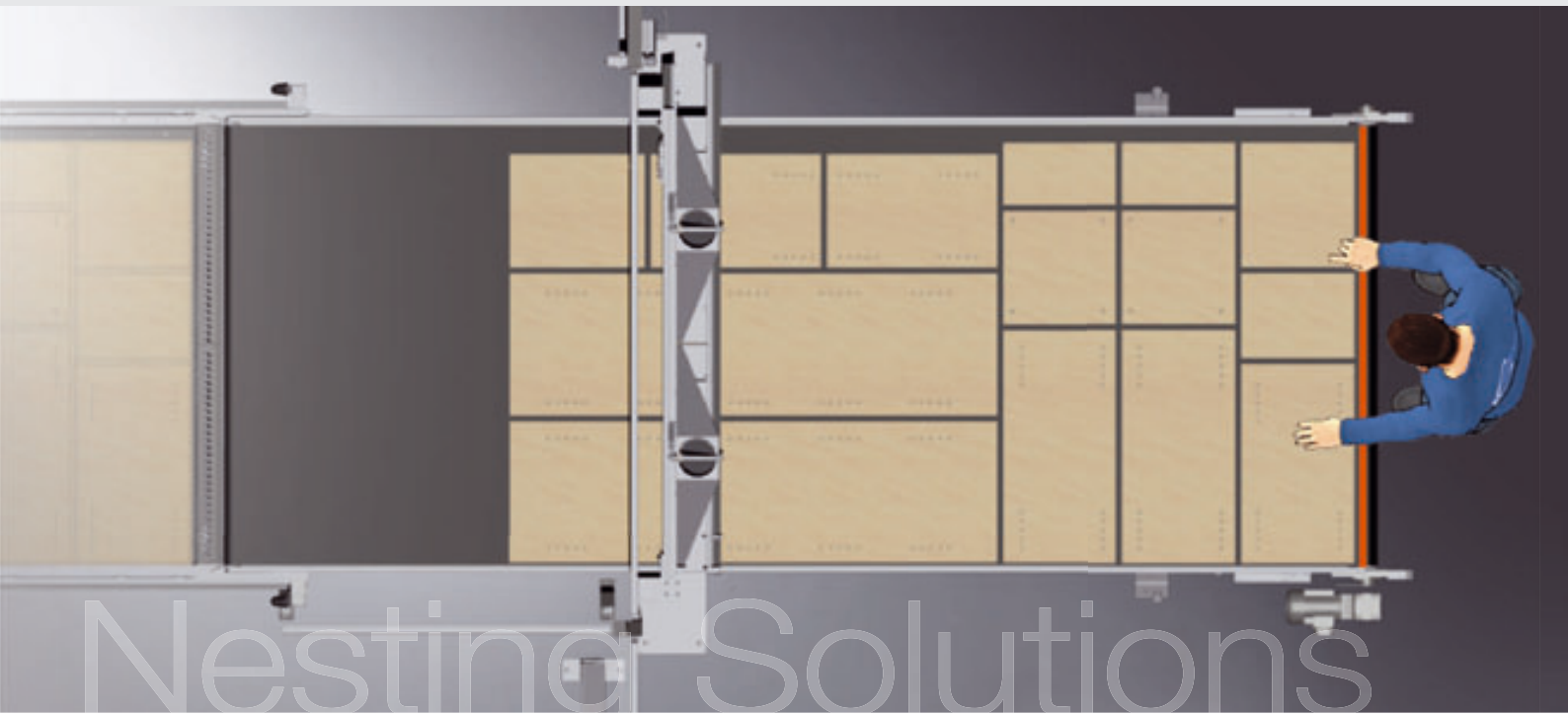

# 512

Matrix Pro +

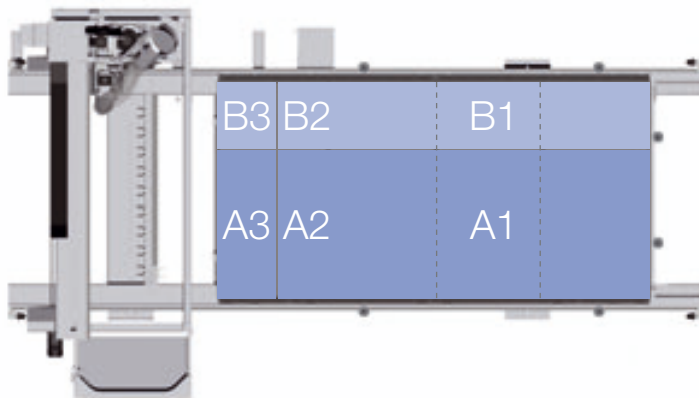

**Matrix-Table PRO+ for Vantech 512 (1550 x 3700 mm)**

10 automatically controlled vacuum fields for boards with dimensions such as:

- A1** = 8 x 4 ft
- A1+A2** = 10 x 4 ft
- A1+A2+A3** = 12 x 4 ft
- A1+B1** = 8 x 5 ft
- A1+A2+B1+B2** = 10 x 5 ft
- A1+A2+A3+B1+B2+B3** = 12 x 5 ft

# 612

Matrix Pro +

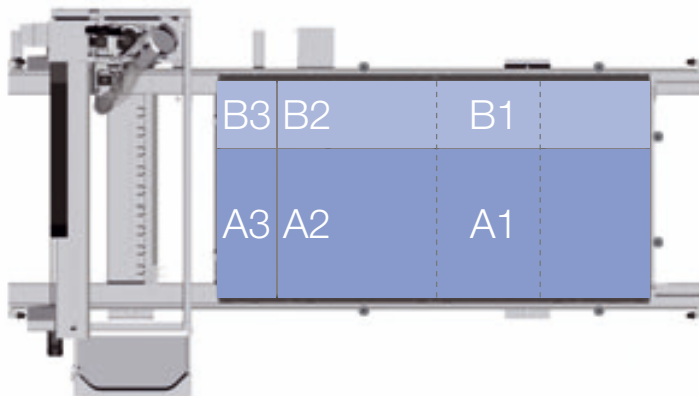

**Matrix-Table PRO+ for Vantech 612 (1850 x 3700 mm)**

10 automatically controlled vacuum fields for boards with dimensions such as:

- A1** = 8 x 4 ft
- A1+A2** = 10 x 4 ft
- A1+A2+A3** = 12 x 4 ft
- A1+B1** = 8 x 6 ft
- A1+A2+B1+B2** = 10 x 6 ft
- A1+A2+A3+B1+B2+B3** = 12 x 6 ft

# Manual and Automatic Concepts

## Basic Machine

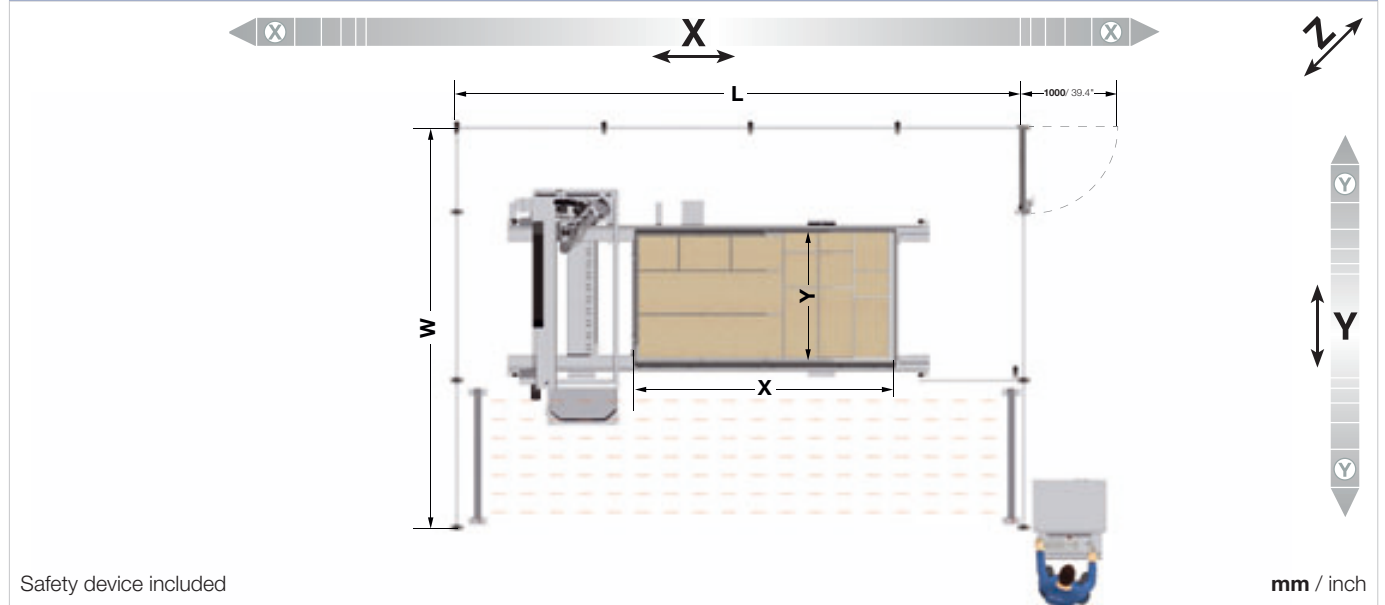

## Handling Concept Outfeed

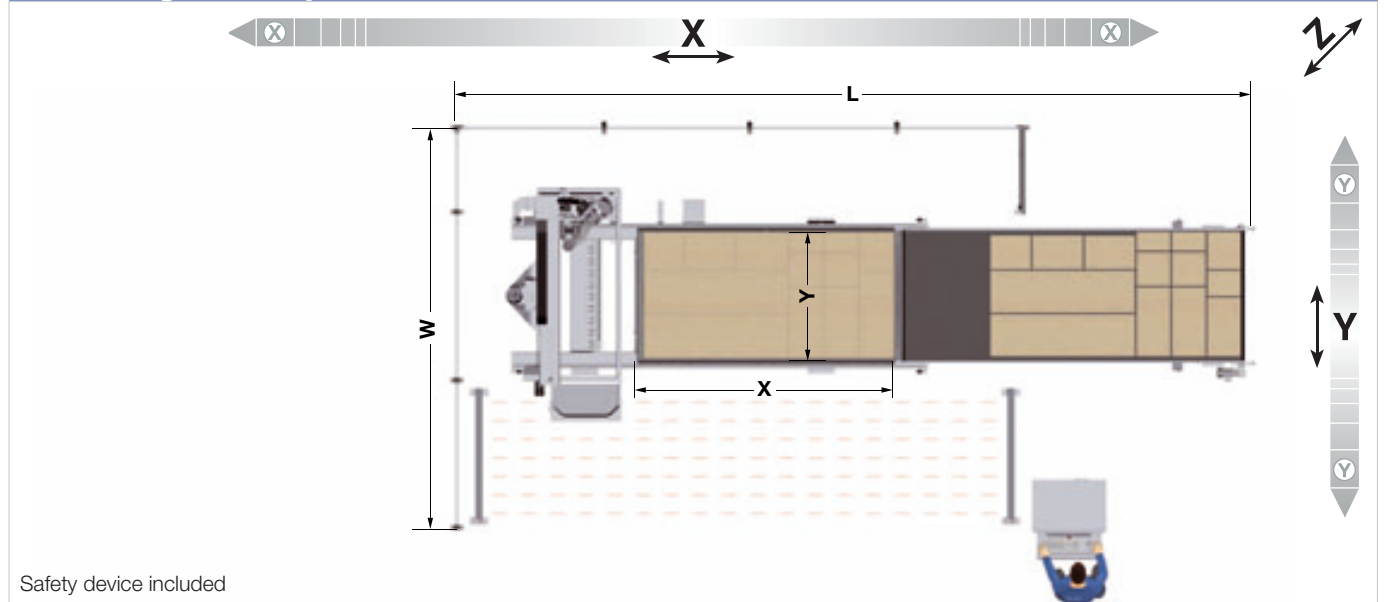

## Handling Concept 1

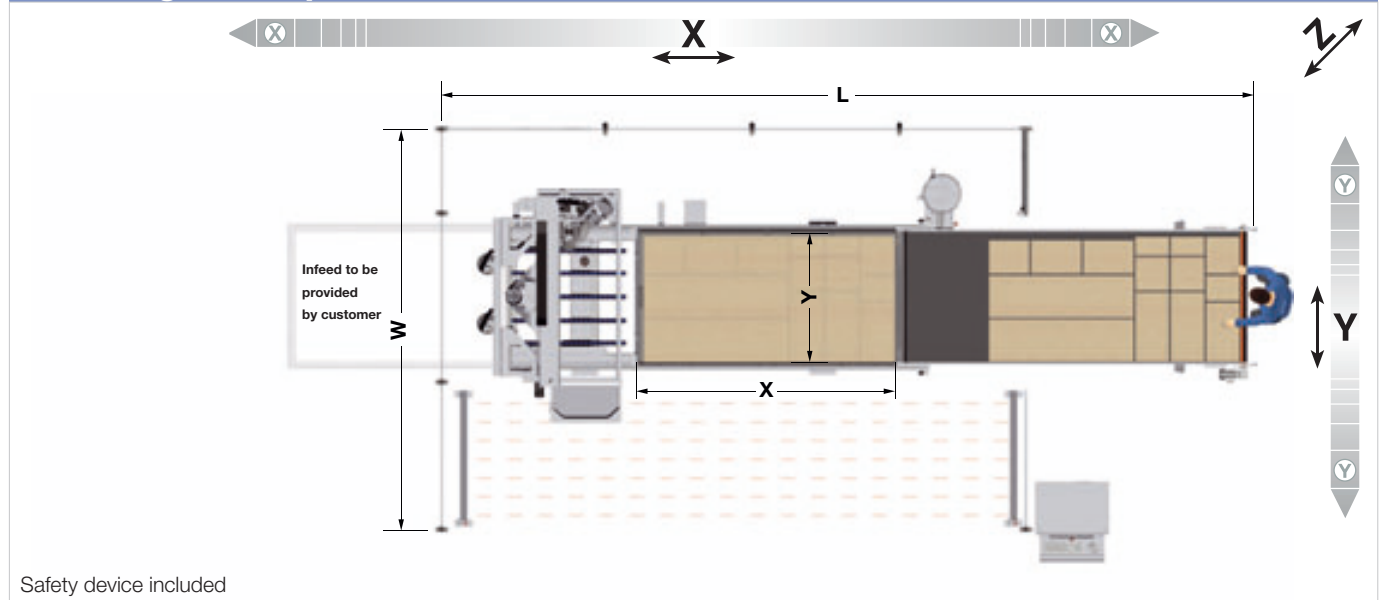

## Handling Concept 2

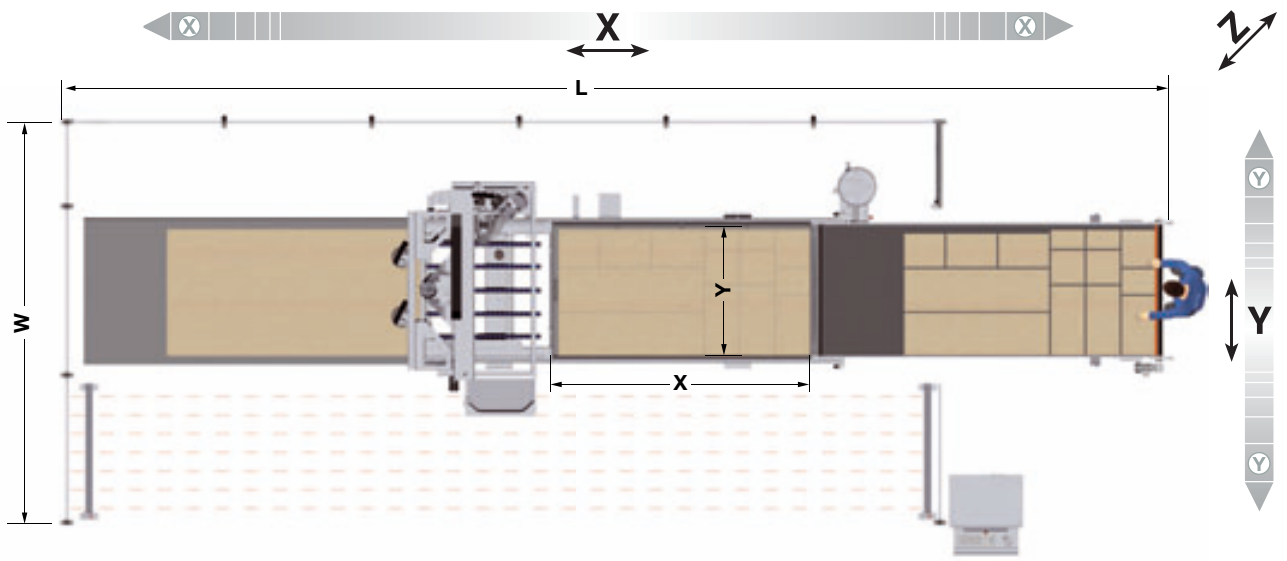

Safety device included

## Handling Concept 2R

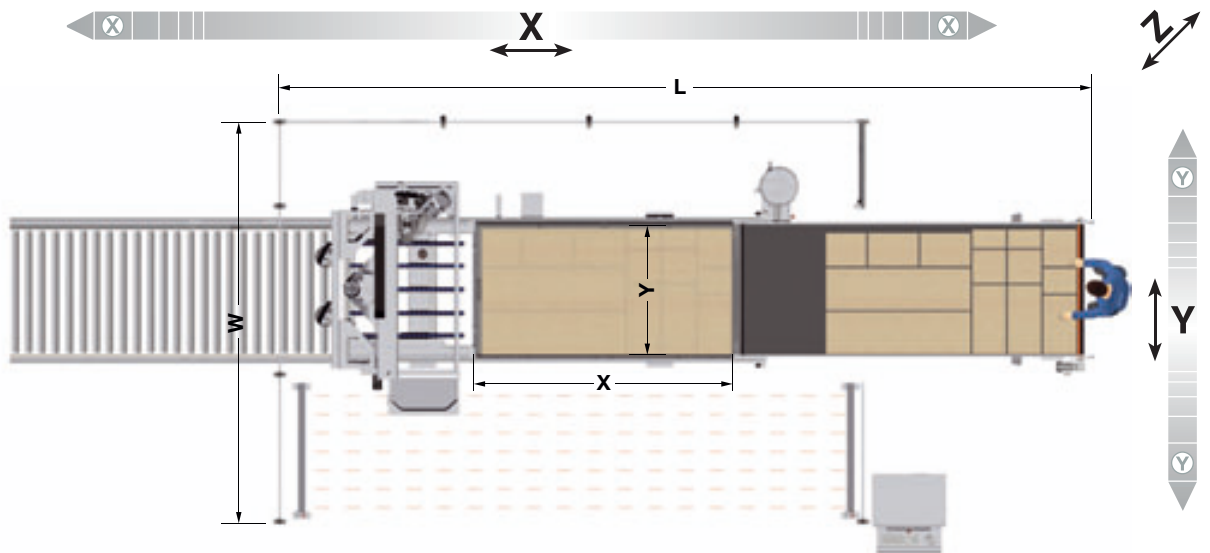

Safety device included

## Handling Concept 3 or 3R

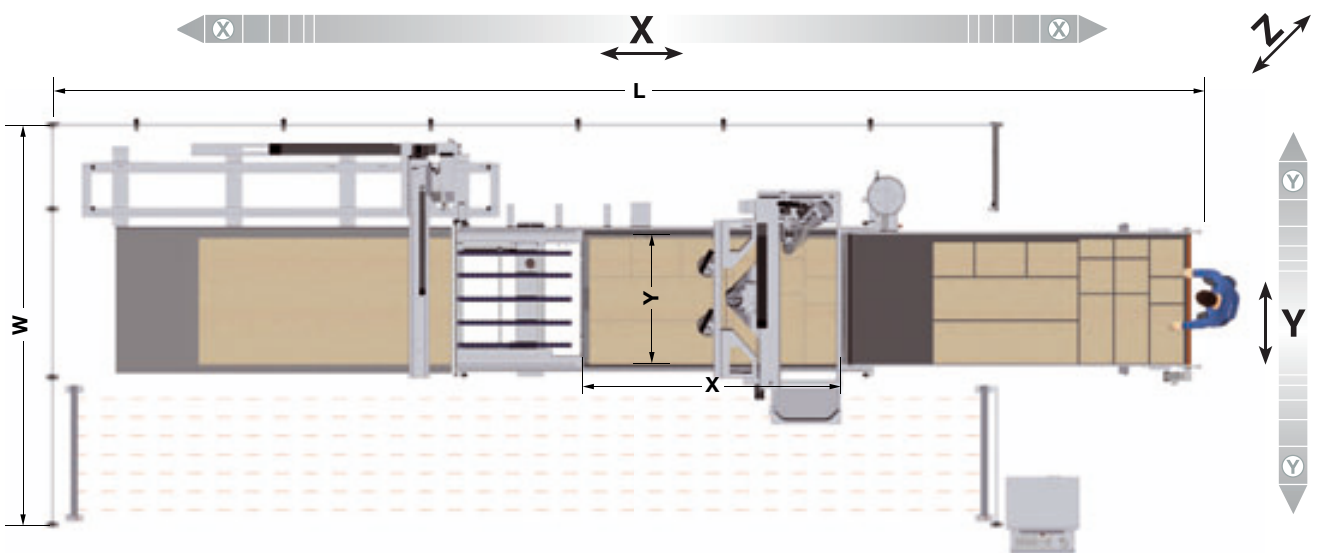

Safety device included

# Nesting with storage



Do you have to routinely deal with short lead times for the delivery of your products? Do your people have to manually inventory material stock to determine what needs to be ordered to complete a job? Do your customers change their orders on short notice, yet expect little delay in the production of the product? The consequences of meeting these demands are far reaching and include lost profitability, production and material utilization inefficiencies, overtime and negative impact upon employee morale.

If this sound familiar to you, its time to learn more about an automated material storage and inventory management solution.



# Nesting Solutions

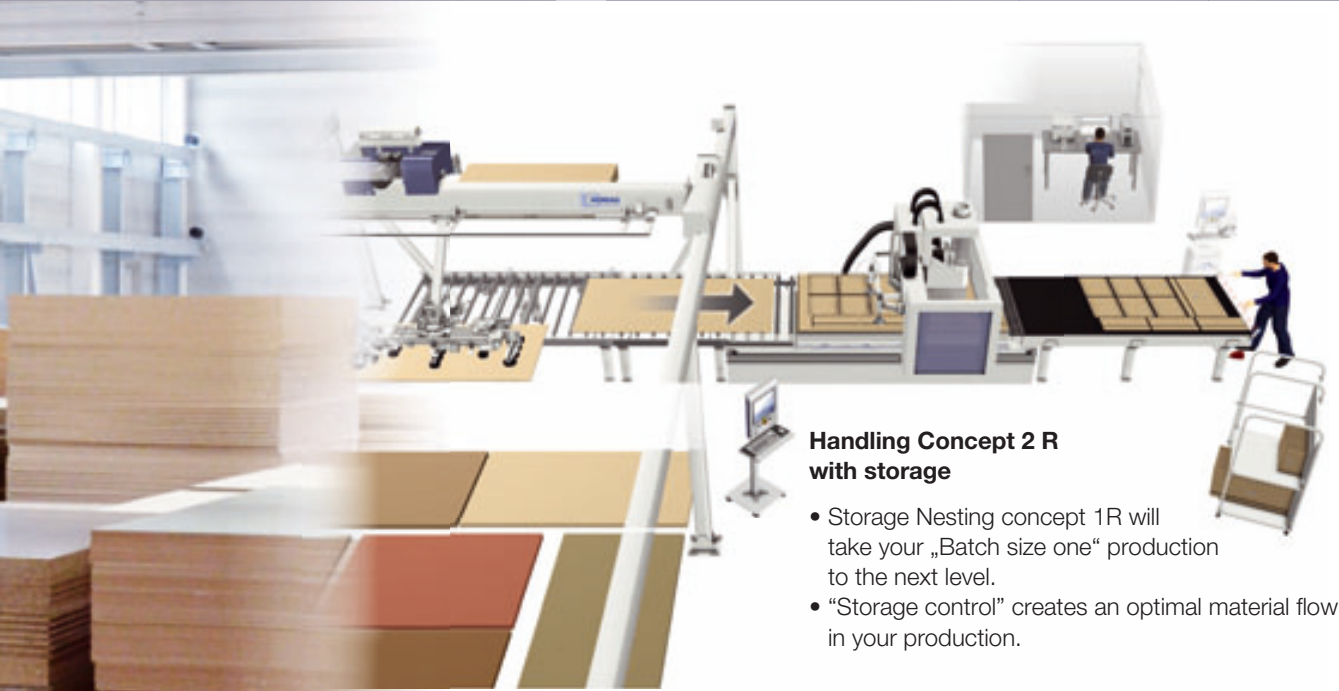

## Handling Concept 2 R with storage

- Storage Nesting concept 1R will take your „Batch size one“ production to the next level.
- “Storage control” creates an optimal material flow in your production.

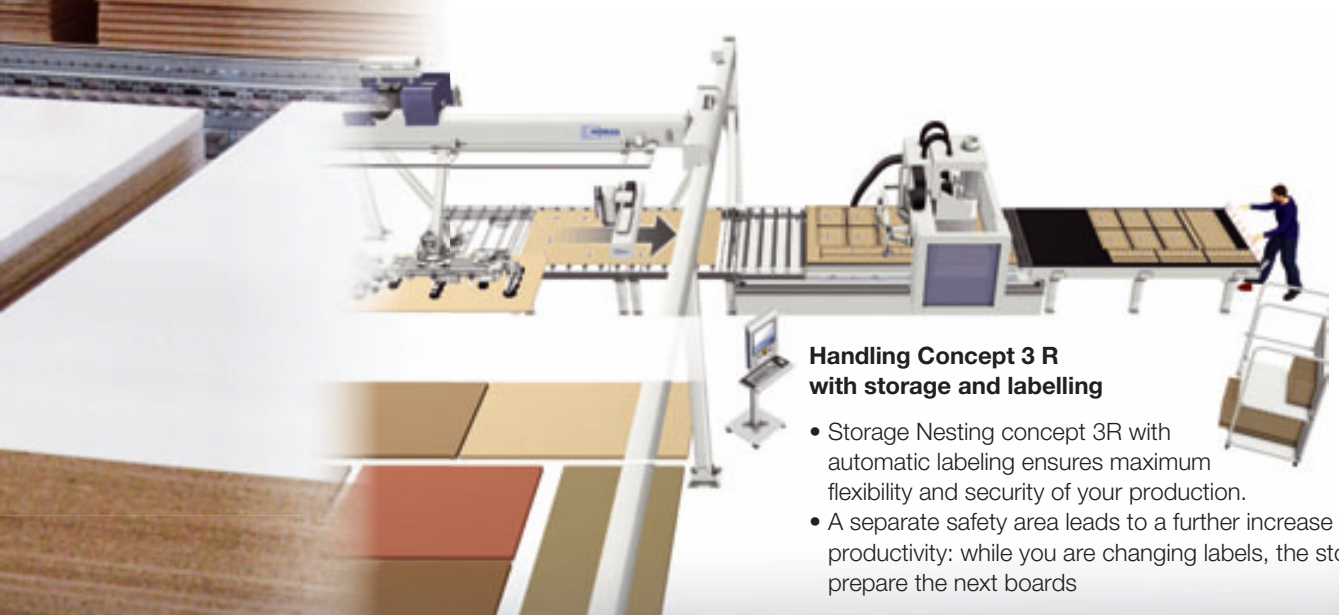

## Handling Concept 3 R with storage and labelling

- Storage Nesting concept 3R with automatic labeling ensures maximum flexibility and security of your production.
- A separate safety area leads to a further increase in your productivity: while you are changing labels, the storage can prepare the next boards

# Options

Need a custom configuration? Our options provide opportunities for a perfect adjustment of your nesting machine to your application.

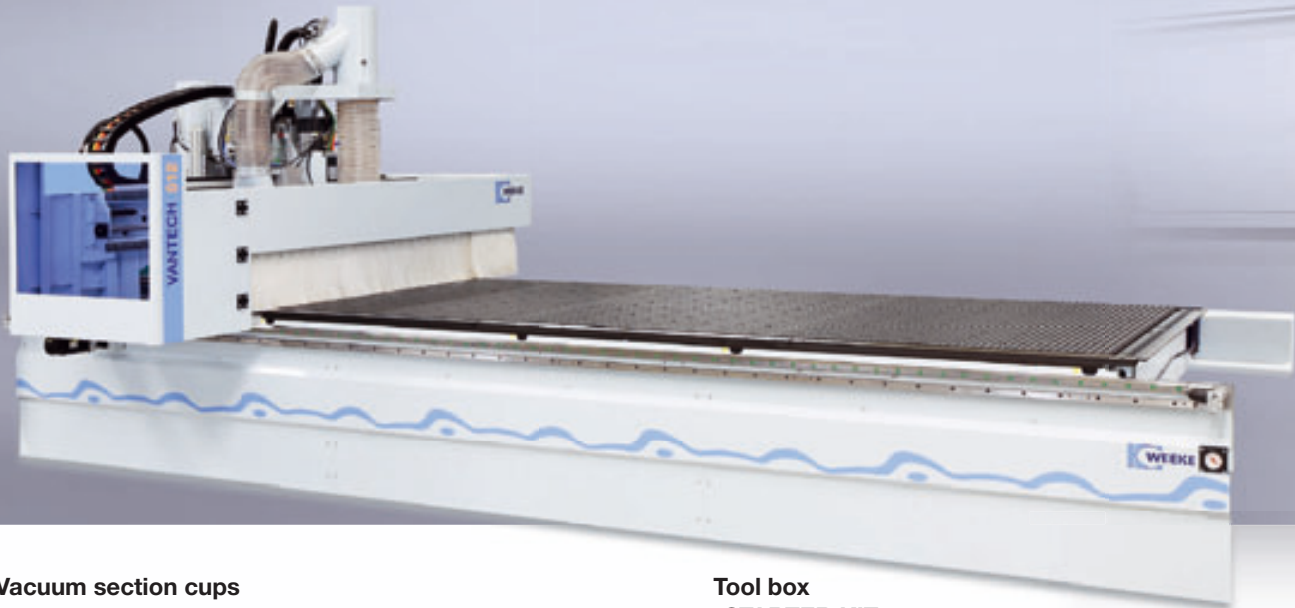

## Vacuum section cups

- High flexibility
- Different sizes and types available as option



## Tool box

»STARTER KIT«



## Stop System Basic / Extension stop system at the rear

- Pneumatically lowerable stop cylinders

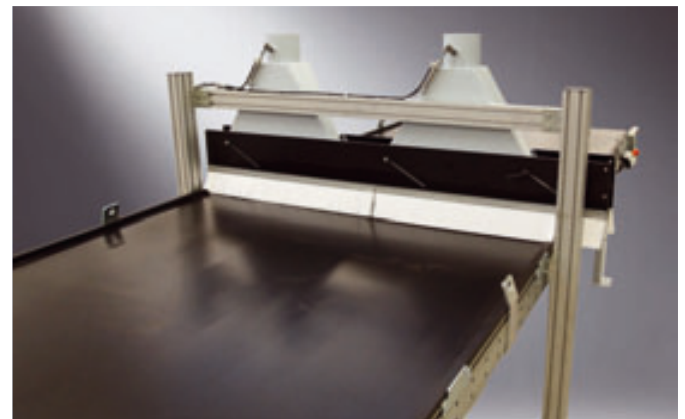

## Dust extraction channel at the outfeed from top

- For cleaning of the workpieces during feeding out



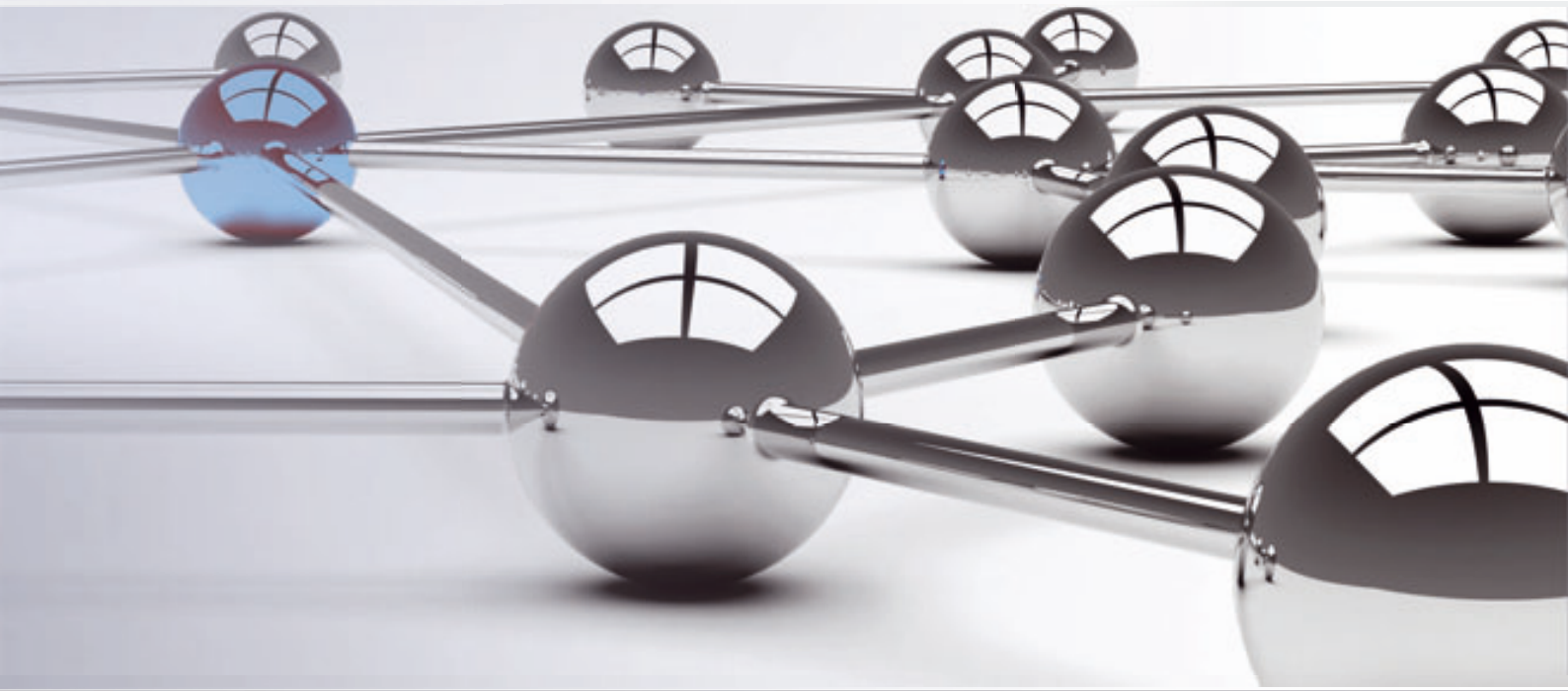

### Air cushion

- Air cushion function between raw board and workpiece
- Positioning of "sensitive materials" with little effort

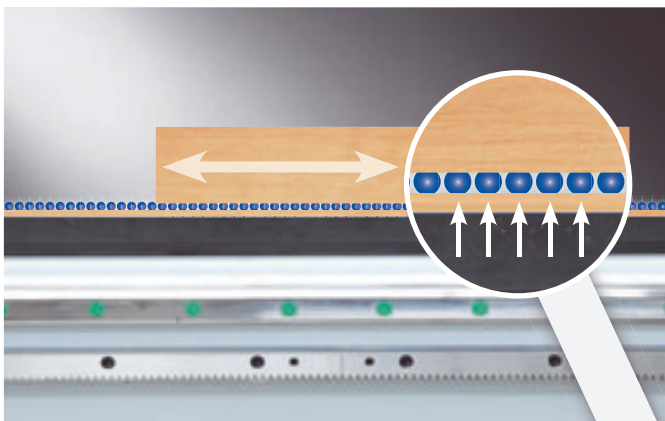

### Label Printing Terminal

- PC, flat screen
- Label printer
- Software: Cute Rite Nesting

### Push & Pull

- Infeed of the new workpiece while pushing off the processed workpiece and cleaning the dummy board.

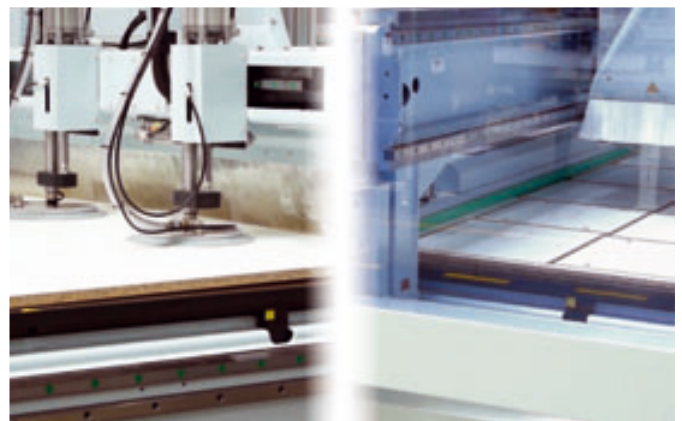

### Air-conditioning

- Air-conditioned switch cabinet

Equipment as described in this brochure is subject to technical changes and further developments. Technical data refer to standard equipment and are not binding for the order.

# Hardware | Software

With this software package you are »Ready to Race«. You will receive one of the most established CNC-programming systems, the woodWOP software, which has proven itself by more than 30.000 installations worldwide.

Please use our website resources:

Worldwide largest forum for woodWOP:

[www.woodWOP-Forum.de](http://www.woodWOP-Forum.de)

Free Download of woodWOP-components:

[www.weeke.com](http://www.weeke.com) → Products → Software

## Standard | Software Machine

### powerControl with powerTouch

- 21,5" Full-HD multitouch display with wide screen 16:9
- Front USB interface
- Ethernet connection 10/100 Mbit



### woodWOP

- Modern software based on Windows®
- More than 30,000 installations worldwide

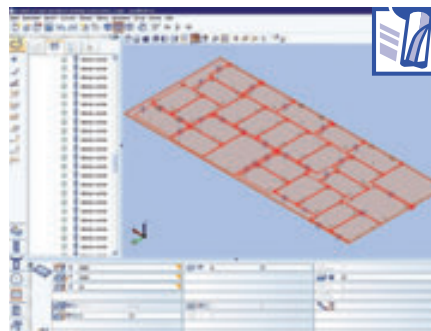

### Production list software

- For management and creation of product lists for individual manufacturing.

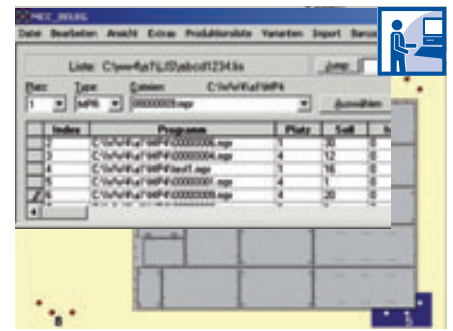

### Hand terminal

- Easy control of main machine functions



### MCC

- Simple control of main machine functions through soft keys
- Graphical loading

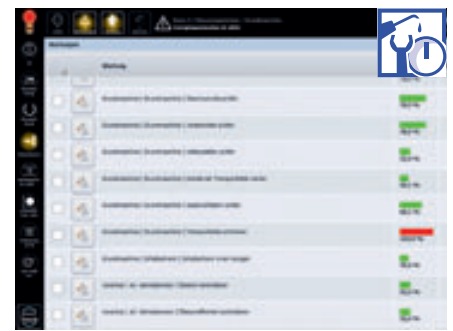

### MMR (Machine data recording) Basic

- Machine Data Recording – collecting and evaluating machine states via time meter and event meter



## Options | Software Office

### woodWOP

- Modern software based on Windows®
- More than 30,000 installations world-wide

### woodWOP DXF Basic

- Interface for CAD-Data Import
- Basis to generate woodWOP programs

### 3D CNC-Simulator

- Simulates the processing in the order it is stored in the NC-program
- Allows time calculation
- Collision check of the vacuum cups

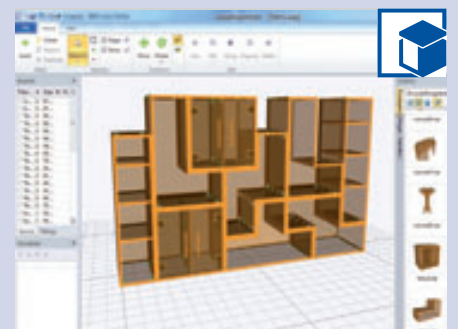
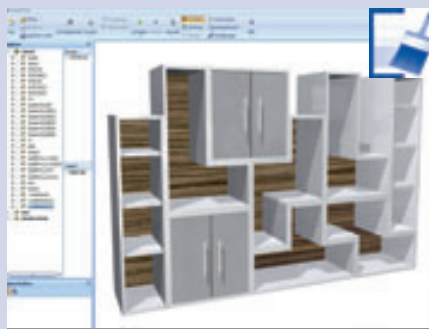
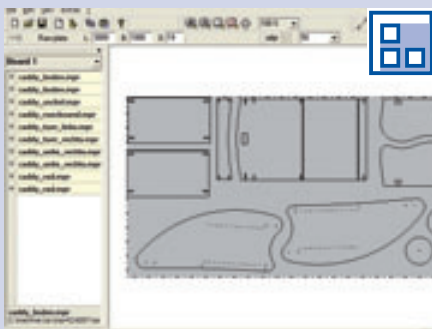
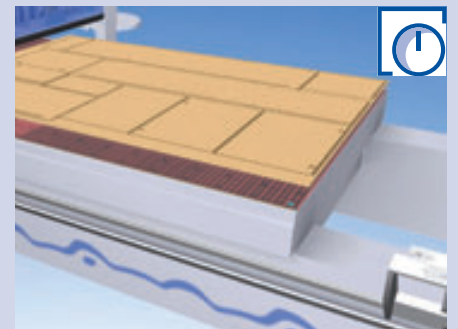
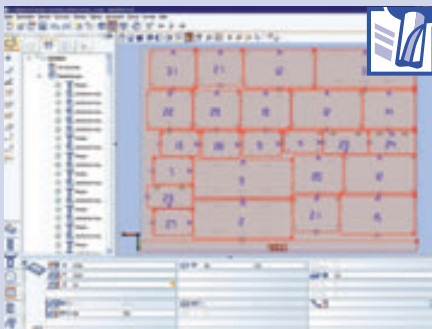

### woodNest Basic

- Software for manual Nesting of shaped parts

### woodVisio

- Objects generated in woodAssembler or Blum Dynalog can be provided with surface materials
- The objects are displayed in a free-standing position

### woodAssembler

- To visualize woodWOP-programs (MPR) in 3D
- Enables the construction of individual workpieces to finished objects



# evolutionary

## powerTouch

powerTouch implements the HOMAG Group's new operating philosophy: **Easy, equal, ergonomic and evolutionary.** The innovative touchscreen operating concept unites design and function to create a totally new control generation.



# ergonomic

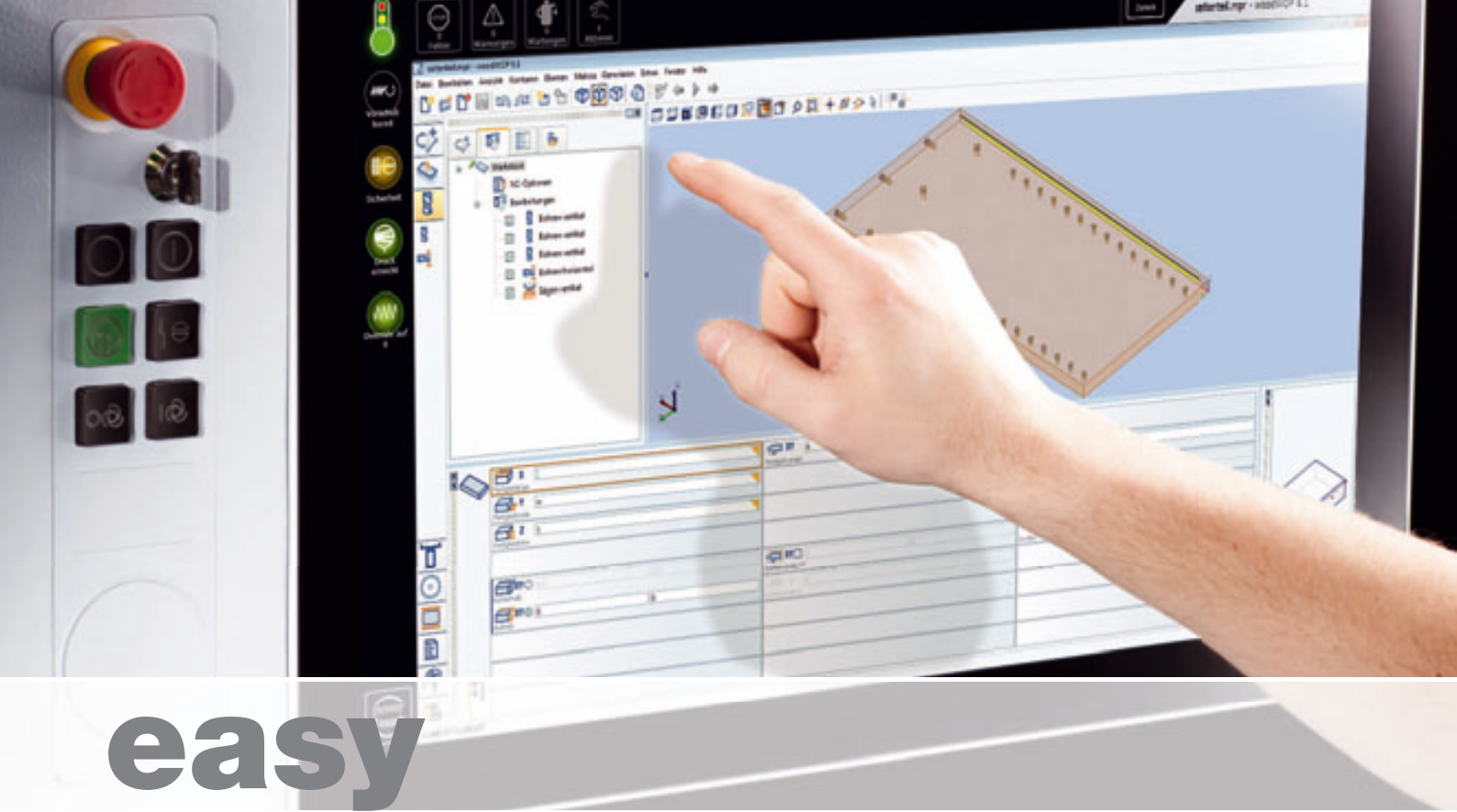

# easy

At the focus of this solution is a large multi-touch monitor in widescreen format, which is used to control machine functions by direct touch contact. The entire user interface has been optimized for touch operation and offers an array of help and assistance functions designed to radically simplify the work experience. Standardized control elements and software modules ensure that all HOMAG Group machines can be operated in

the same way using powerTouch. They differ only in terms of a few machine-specific details.

This does not only simplify the operation of different machines, but also makes for greater efficiency by significantly reduced time for servicing and training.

# equal



# Nesting Software

## Solutions for nesting of components

### Your benefits

- Advanced optimization allows material costs to be reduced and overall processing times to be lowered.

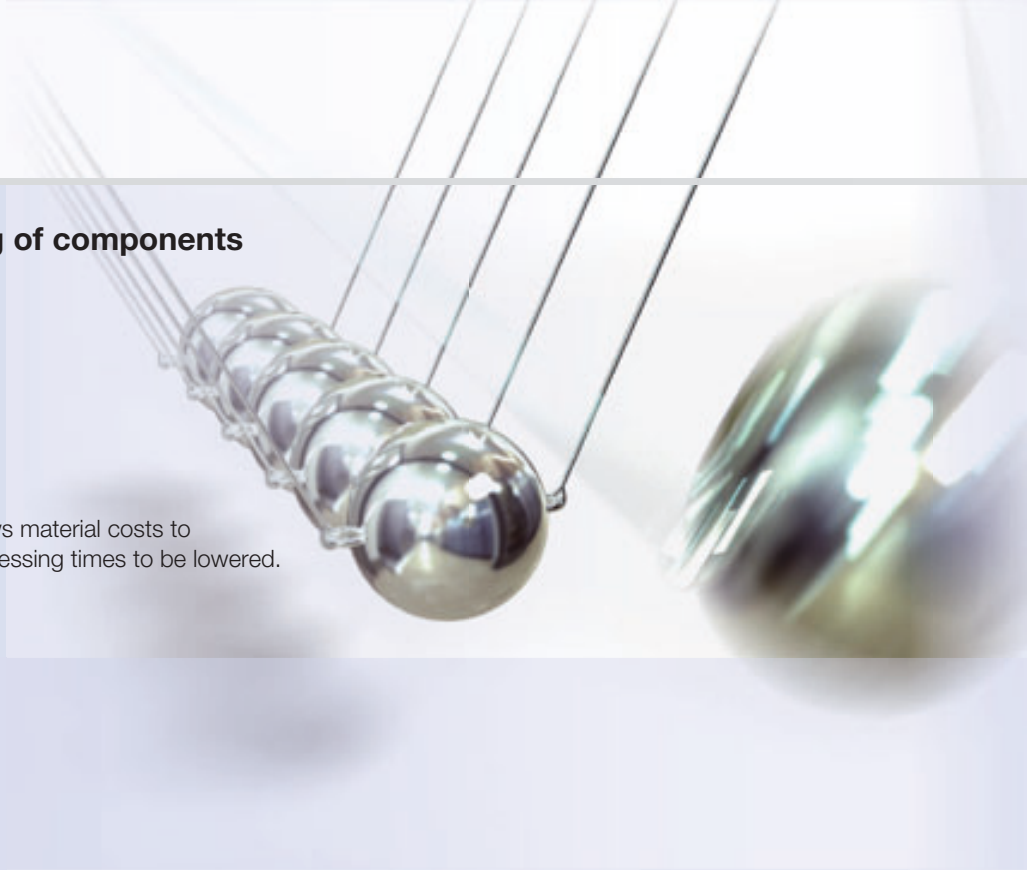

### Cut Rite Nesting

**Cut Rite**, the optimization software of the HOMAG Group, is used for cutting boards on sawing machines as well as nesting machines. The modular structure of the software allows users already controlling their sawing machine via **Cut Rite** to integrate the nesting module without problems.

### Highlights

- Board library and calculation of material costs
- Labeling in the office incl. layout editor
- Additional modules can be applied optionally, e. g. for stock management

### Cut Rite Nesting

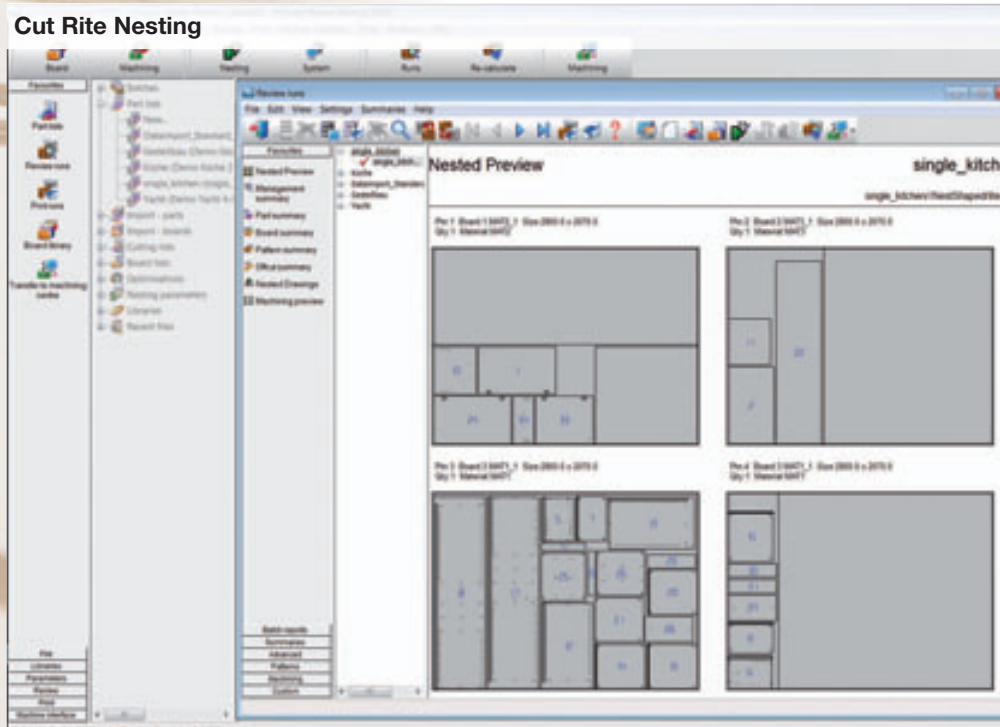

# Cut Rite Nesting | Functions

## Cut Rite Nesting | Parts list

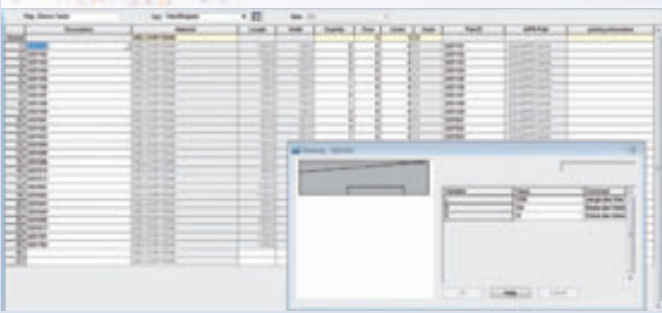

## Cut Rite Nesting | Parts list

- Can be manually created by entering individual woodWOP-files
- Can be imported from other programmes, e.g. excel charts
- Can be optionally edited and processed
- Import of up to 50 woodWOP-variables
- The program optimizes the parts list sorted according to material or any other parameter

## Cut Rite Nesting | Label designer



## Cut Rite Nesting | Label designer

- With the integrated label designer you can create labels at your workplace and print them directly in the office
- This function does not replace the automatic printing function at the machine

## Cut Rite Nesting | Editor

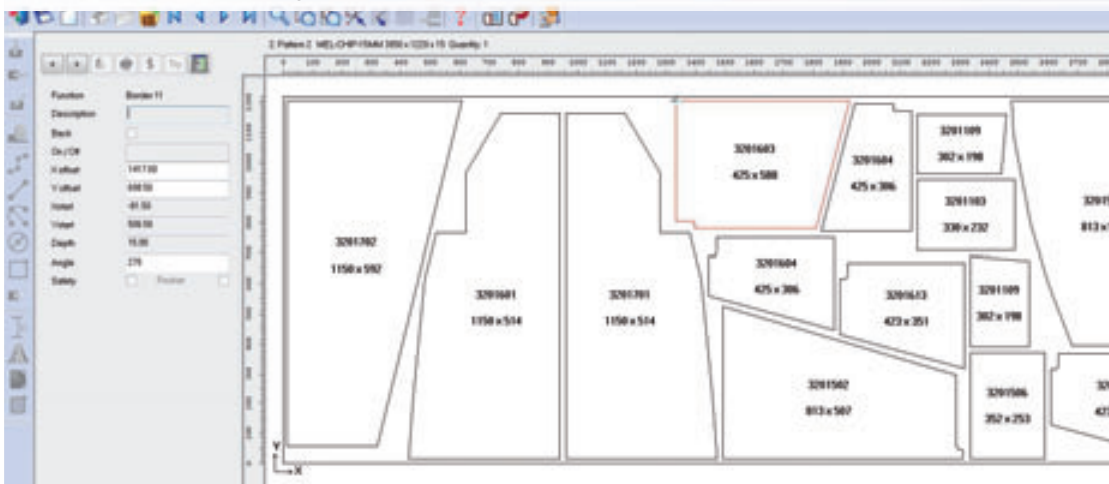

## Cut Rite Nesting | Editor

As needed, the optimization result can be manually modified, e.g. adding filling parts.

## Cut Rite Nesting | Result



## Cut Rite Nesting | Cutting plan templates



## Cut Rite Nesting | Result

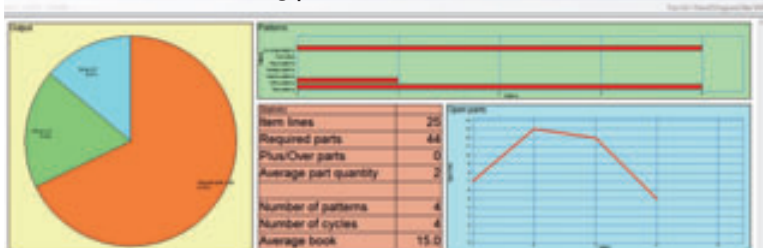

## Cut Rite Nesting | Clear structured results

Cut Rite provides a clear and structured presentation of the results of the optimization. For every optimization run several reports are issued which can be individually configured.

## Cut Rite Nesting | Cutting plan templates

It is possible to create cutting plan templates, e.g. for furniture fronts, in order to guarantee a continuous texture over several individual parts.

# Technical Data



For the Success of Original Technology  
A campaign of the VDMA

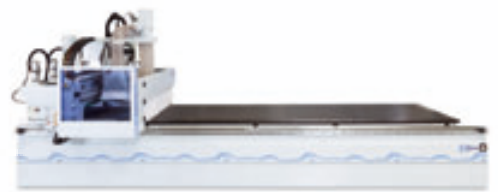

		<b>X</b>	<b>Y</b>	<b>Z</b>
Working field	<b>Vantech 480</b>	<b>2520</b> / 99.2	<b>1250</b> / 49.2	<b>100</b> / 3.9
	<b>Vantech 510</b>	<b>3100</b> / 122.0	<b>1550</b> / 61.0	<b>100</b> / 3.9
	<b>Vantech 512</b>	<b>3700</b> / 145.7	<b>1550</b> / 61.0	<b>100</b> / 3.9
	<b>Vantech 612</b>	<b>3700</b> / 145.7	<b>1850</b> / 72.8	<b>100</b> / 3.9
Travel range	<b>Vantech 480</b>	<b>3710</b> / 146.1	<b>1660</b> / 65.4	<b>245</b> / 9.6
	<b>Vantech 510</b>	<b>4300</b> / 169.3	<b>1965</b> / 77.4	<b>245</b> / 9.6
	<b>Vantech 512</b>	<b>4900</b> / 193.0	<b>1965</b> / 77.4	<b>245</b> / 9.6
	<b>Vantech 612</b>	<b>4900</b> / 193.0	<b>2257</b> / 88.9	<b>245</b> / 9.6

			<b>L</b>	<b>W</b>
Floor space	Manual Concepts*			
	Basic Machine	<b>Vantech 480</b>	<b>6580</b> / 259.1	<b>4420</b> / 172.0
		<b>Vantech 510</b>	<b>7080</b> / 278.7	<b>4880</b> / 192.1
		<b>Vantech 512</b>	<b>7580</b> / 298.4	<b>4880</b> / 192.1
		<b>Vantech 612</b>	<b>7580</b> / 298.4	<b>5130</b> / 202.0
	Handling Concept Outfeed	<b>Vantech 480</b>	<b>8100</b> / 318.9	<b>4420</b> / 172.0
		<b>Vantech 510</b>	<b>9800</b> / 385.8	<b>4880</b> / 192.1
		<b>Vantech 512</b>	<b>10290</b> / 405.1	<b>4880</b> / 192.1
		<b>Vantech 612</b>	<b>10290</b> / 405.1	<b>5130</b> / 202.0
	Automatic Concepts*			
	Handling Concept 1	<b>Vantech 480</b>	<b>8320</b> / 327.6	<b>4420</b> / 172.0
		<b>Vantech 510</b>	<b>10050</b> / 395.7	<b>4880</b> / 192.1
		<b>Vantech 512</b>	<b>10540</b> / 415.0	<b>4880</b> / 192.1
		<b>Vantech 612</b>	<b>10540</b> / 395.7	<b>5130</b> / 202.0
	Handling Concept 2	<b>Vantech 480</b>	<b>10300</b> / 405.5	<b>4420</b> / 172.0
		<b>Vantech 510</b>	<b>12550</b> / 494.1	<b>4880</b> / 192.1
		<b>Vantech 512</b>	<b>13790</b> / 542.9	<b>4880</b> / 192.1
		<b>Vantech 612</b>	<b>13790</b> / 542.9	<b>5130</b> / 202.0
	Handling Concept 2R	<b>Vantech 480</b>	<b>11800</b> / 464.6	<b>4420</b> / 172.0
		<b>Vantech 510</b>	<b>13950</b> / 549.2	<b>4880</b> / 192.1
		<b>Vantech 512</b>	<b>14660</b> / 577.2	<b>4880</b> / 192.1
		<b>Vantech 612</b>	<b>14660</b> / 577.2	<b>5130</b> / 202.0
	Handling Concept 3	<b>Vantech 480</b>	<b>11040</b> / 434.6	<b>4420</b> / 172.0
		<b>Vantech 510</b>	<b>13100</b> / 515.7	<b>4880</b> / 192.1
		<b>Vantech 512</b>	<b>14290</b> / 562.6	<b>4880</b> / 192.1
		<b>Vantech 612</b>	<b>14290</b> / 562.6	<b>5330</b> / 209.8
	Handling Concept 3R	<b>Vantech 480</b>	<b>13400</b> / 527.6	<b>4420</b> / 172.0
		<b>Vantech 510</b>	<b>15300</b> / 602.4	<b>4880</b> / 192.1
		<b>Vantech 512</b>	<b>15840</b> / 623.6	<b>4880</b> / 192.1
		<b>Vantech 612</b>	<b>15840</b> / 623.6	<b>5330</b> / 209.8

\*Subject to technical changes

mm / inch

Vector speed X/Y - Z-axis	m/min	96 - 25
Compressed air connection	inch	R ½
Compressed air required	bar	7
Dust extraction port	mm	Ø 200*
Dust extraction volume	m³/h	min. 3170**
Electrical power – total connection load	kW	27.5**

\*\* Basic Machine

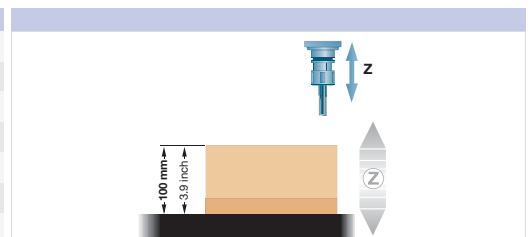

Member of the HOMAG Group



**WEEKE Bohrsysteme GmbH**

Benzstrasse 10-16  
33442 Herzebrock-Clarholz  
GERMANY

Tel.: +49 5245 445-0

Fax: +49 5245 445-44 139

info@weeke.de | www.weeke.com